

## Sliding-gate operators

FA01955-EN

CE

EAC



**BXV04AGE    BXV06AGE    BXV10AGE**  
**BXV04AGM    BXV06AGM    BXV10AGM**

INSTALLATION MANUAL

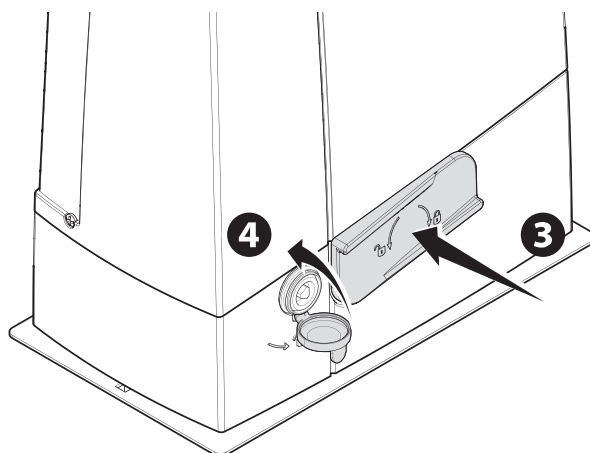
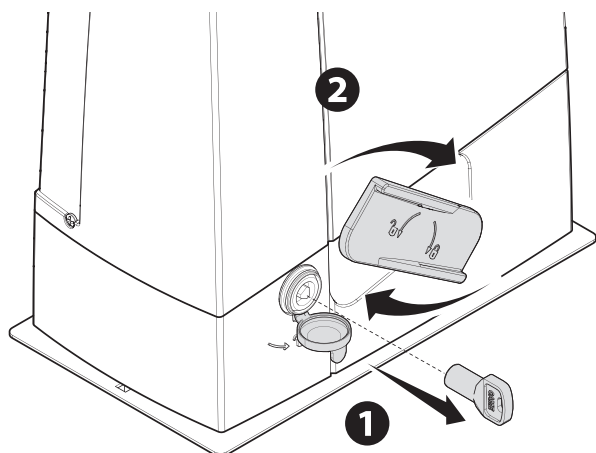
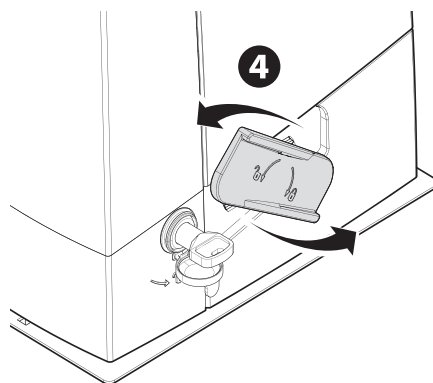
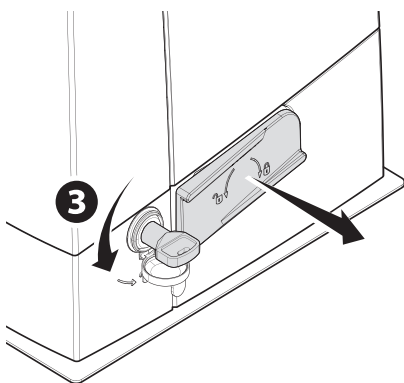
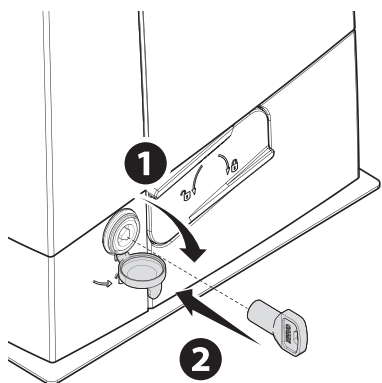

**⚠ Important safety instructions.****⚠ Please follow all of these instructions. Improper installation may cause serious bodily harm.****⚠ Before continuing, please also read the general precautions for users.**

Only use this product for its intended purpose. Any other use is hazardous.

- The manufacturer cannot be held liable for any damage caused by improper, unreasonable or erroneous use.
- This product is defined by the Machinery Directive (2006/42/EC) as partly completed machinery.
- Partly completed machinery means an assembly which is almost machinery but which cannot in itself perform a specific application.
- Partly completed machinery is only intended to be incorporated into or assembled with other machinery or other partly completed machinery or equipment thereby forming machinery to which the Machinery Directive (2006/42/EC) applies.
- The final installation must comply with the Machinery Directive (2006/42/EC) and the European reference standards in force.
- The manufacturer declines any liability for using non-original products, which would also void the warranty.
- All operations indicated in this manual must be carried out exclusively by skilled and qualified personnel and in full compliance with the regulations in force.
- The device must be installed, wired, connected and tested according to good professional practice, in compliance with the standards and laws in force.
- Make sure the mains power supply is disconnected during all installation procedures.
- Check that the temperature ranges given are suitable for the installation site.
- Do not install on slopes i.e. any surfaces that are not perfectly level.
- Do not install the operator on surfaces that could yield and bend. If necessary, add suitable reinforcements to the anchoring points.
- Make sure that no direct jets of water can wet the product at the installation site (sprinklers, water cleaners, etc.).
- Make sure you have set up a suitable dual-pole cut-off device along the power supply that is compliant with the installation rules. It should completely cut off the power supply according to category III surcharge conditions.
- Demarcate the entire site properly to prevent unauthorised personnel from entering, especially minors.
- In case of manual handling, have one person for every 20 kg that needs hoisting; for non-manual handling, use proper hoisting equipment in safe conditions.
- Use suitable protection to prevent any mechanical hazards due to persons loitering within the operating range of the operator.
- The electrical cables must pass through special pipes, ducts and cable glands in order to guarantee adequate protection against mechanical damage.
- The electrical cables must not touch any parts that may overheat during use (such as the motor and transformer).
- Before installation, check that the guided part is in good mechanical condition, and that it opens and closes correctly.
- The product cannot be used to automate any guided part that includes a pedestrian gate, unless it can only be enabled when the pedestrian gate is secured.
- Make sure that nobody can become trapped between the guided and fixed parts, when the guided part is set in motion.
- Use additional protection to prevent your fingers from being crushed between the pinion and rack.
- All fixed controls must be clearly visible after installation, in a position that allows the guided part to be directly visible, but far away from moving parts. In the case of a hold-to-run control, this must be installed at a minimum height of 1.5 m from the ground and must not be accessible to the public.
- Where operated with a hold-to-run control, install a STOP button to disconnect the main power supply to the operator, to block movement of the guided part.
- If not already present, apply a permanent tag that describes how to use the manual release mechanism close to it.
- Make sure that the operator has been properly adjusted and that the safety and protection devices and the manual release are working properly.
- Before handing over to the final user, check that the system complies with the harmonised standards and the essential requirements of the Machinery Directive (2006/42/EC).
- Any residual risks must be indicated clearly with proper signage affixed in visible areas, and explained to end users.
- Put the machine's ID plate in a visible place when the installation is complete.
- If the power supply cable is damaged, it must be immediately replaced by the manufacturer or by an authorised technical support service, or in any case, by qualified staff, to prevent any risk.
- Keep this manual inside the technical folder along with the manuals of all the other devices used for your automation system.
- Make sure to hand over to the end user all the operating manuals of the products that make up the final machinery.
- The product, in its original packaging supplied by the manufacturer, must only be transported in a closed environment (railway carriage, containers, closed vehicles).
- If the product malfunctions, stop using it and contact customer services at <https://www.came.com/global/en/contact-us> or via the telephone number on the website.

📖 The manufacture date is provided in the production batch printed on the product label. If necessary, contact us at <https://www.came.com/global/en/contact-us>.

📖 The general conditions of sale are given in the official CAME price lists.

## Main points of danger for people

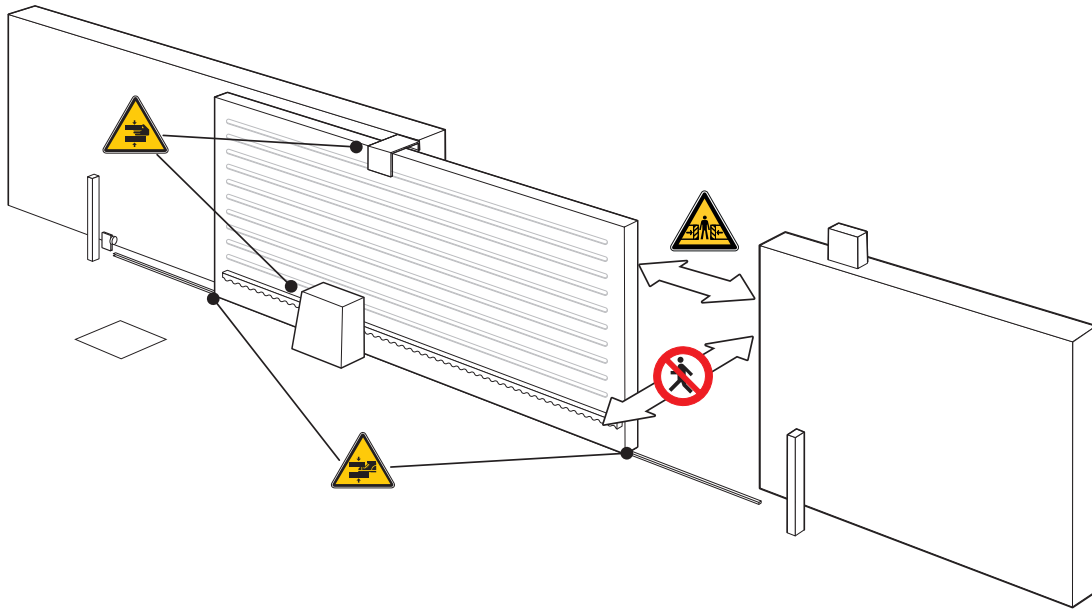

No transiting while the barrier is moving.



Danger of crushing.



Risk of trapping hands.



Risk of trapping feet.

## DISMANTLING AND DISPOSAL

CAME S.p.A. employs an Environmental Management System at its premises. This system is certified and compliant with the UNI EN ISO 14001 standard to ensure that the environment is respected and safeguarded. Please continue safeguarding the environment. At CAME we consider it one of the fundamentals of our operating and market strategies. Please follow these brief disposal guidelines:

### DISPOSING OF THE PACKAGING

The packaging materials (cardboard, plastic, etc.) can be disposed of easily as solid urban waste, separated for recycling.

Before dismantling and disposing of the product, please always check the local laws in force.

### DISPOSE OF THE PRODUCT RESPONSIBLY.

### DISPOSING OF THE PRODUCT

Our products are made of various materials. Most of these materials (aluminium, plastic, iron and electrical cables) are classified as solid urban waste. They can be separated for recycling and disposed of at authorised waste treatment plants.

Other components (electronic boards, transmitter batteries, etc.) may contain pollutants.





These must be removed and disposed of by an authorised waste disposal and recycling firm.

It is always advisable to check the specific laws that apply in your area.

### DISPOSE OF THE PRODUCT RESPONSIBLY.

### Key

---

-  This symbol shows which parts to read carefully.
-  This symbol shows which parts describe safety issues.
-  This symbol shows what to tell users.
-  The measurements, unless otherwise stated, are in millimetres.

### Description

---

#### 801MS-0570

BXV04AGE - Operator with 24 V motor, featuring a control board with graphic display, Adaptive Speed & Torque Technology, CXN BUS, B1-B2 second contact output, on-board radio decoding, movement and obstruction detecting device for gates weighing up to 400 kg that are up to 14 m long. RAL7024 grey cover.

#### 801MS-0580

BXV06AGE - Operator with 24 V motor, featuring a control board with graphic display, Adaptive Speed & Torque Technology, CXN BUS, B1-B2 second contact output, on-board radio decoding, movement and obstruction detecting device for gates weighing up to 600 kg that are up to 18 m long. RAL7024 grey cover.

#### 801MS-0590

BXV10AGE - Operator with 24 V motor, featuring a control board with graphic display, Adaptive Speed & Torque Technology, CXN BUS, B1-B2 second contact output, on-board radio decoding, movement and obstruction detecting device for gates weighing up to 1000 kg that are up to 20 m long. RAL7024 grey cover.

#### 801MS-0650

BXV04AGM - Operator with 24 V motor, featuring a control board with graphic display, Adaptive Speed & Torque Technology, CXN BUS, B1-B2 second contact output, magnetic limit switches, on-board radio decoding, movement and obstruction detecting device for gates weighing up to 400 kg that are up to 14 m long. RAL7024 grey cover.

#### 801MS-0660

BXV06AGM - Operator with 24 V motor, featuring a control board with graphic display, Adaptive Speed & Torque Technology, CXN BUS, B1-B2 second contact output, magnetic limit switches, on-board radio decoding, movement and obstruction detecting device for gates weighing up to 600 kg that are up to 18 m long. RAL7024 grey cover.

#### 801MS-0670

BXV10AGM - Operator with 24 V motor, featuring a control board with graphic display, Adaptive Speed & Torque Technology, CXN BUS, B1-B2 second contact output, magnetic limit switches, on-board radio decoding, movement and obstruction detecting device for gates weighing up to 1000 kg that are up to 20 m long. RAL7024 grey cover.

### Intended use

---

Sliding gate solution for residential buildings and apartment blocks

-  Any installation and/or use other than that specified in this manual is forbidden.

## Description of parts

### Operator

- ❶ Cover
- ❷ Housing for the RLB card
- ❸ Board-holder support
- ❹ Fastening screw cover
- ❺ Gearmotor
- ❻ Anchoring plate
- ❼ Mechanical limit switch (BXV04AGE - BXV06AGE - BXV10AGE)
- ❽ Transformer
- ❾ Magnetic limit switch (BXV04AGM - BXV06AGM - BXV10AGM)
- ❿ Housing for SMA sensors
- ⓫ Housing for two emergency batteries\*
- ⓬ Board protection cover
- ⓭ Control board
- ⓮ Control board holder
- ⓯ Housing for the RGSM001/S or RSLV001 module
- ⓰ Housing for thermostat with cartridge
- ⓱ Release lever
- ⓲ Lock
- ⓳ Magnetic limit-switch tabs (BXV04AGM - BXV06AGM - BXV10AGM)
- ⓴ Mechanical limit-switch tabs (BXV04AGE - BXV06AGE - BXV10AGE)

\*Only use emergency batteries 5Ah (88018-0029).

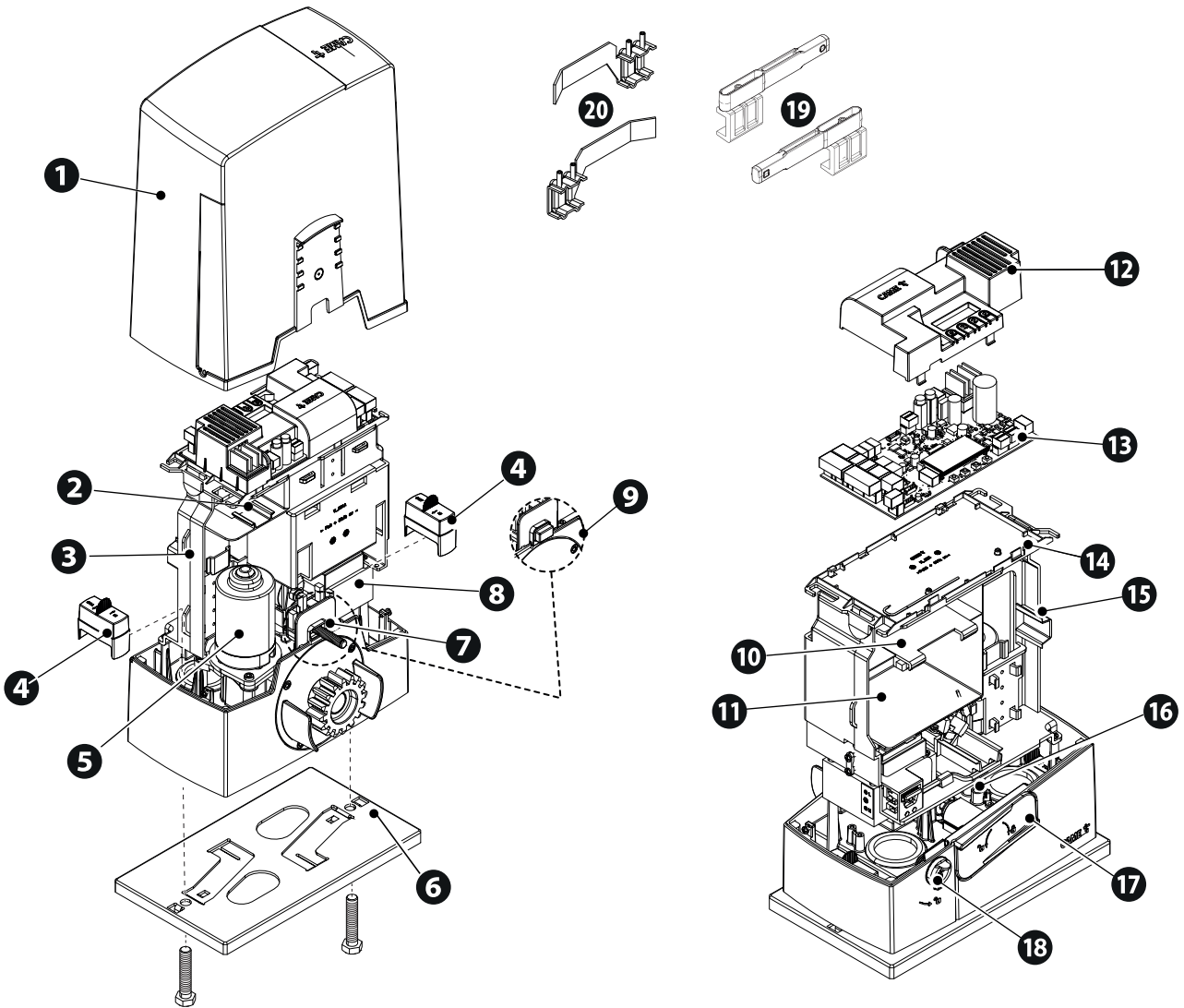

## Control board

The functions on the input and output contacts, the time settings and user management are set and viewed on the display.

All connections are protected by quick fuses.

For the system to work properly, before fitting any plug-in card, DISCONNECT THE MAIN POWER SUPPLY and remove any batteries.

Before working on the control panel, disconnect the mains power supply and remove the batteries, if any.

- |  |  |
|--|--|
| <ul style="list-style-type: none"> <li>❶ Terminal board for connecting control devices</li> <li>❷ Terminal board for connecting the safety devices</li> <li>❸ Terminal board for connecting the signalling devices</li> <li>❹ Terminal board for B1-B2 output</li> <li>❺ Connector for the RIOCN8WS module</li> <li>❻ Terminal board for BUS accessories</li> <li>❼ Connector for the CLOCK card</li> <li>❽ Memory Roll card connector</li> <li>❾ Terminal board for connecting the limit switches</li> <li>❿ Accessories fuse</li> <li>⓫ Control board fuse</li> <li>⓬ Terminal board for power supply to the control board</li> <li>⓭ Line fuse</li> </ul> | <ul style="list-style-type: none"> <li>⓮ Power supply terminal board</li> <li>⓯ Terminal board for connecting the gearmotor</li> <li>⓰ Terminal board for connecting the encoder</li> <li>⓱ Display</li> <li>⓲ Programming buttons</li> <li>⓳ Connector for CAME KEY</li> <li>⓴ RSE_1 connector for RSE card</li> <li>⓵ RSE_2 connector for RSE card</li> <li>⓶ Terminal block associated with the RSE_1 connector for paired or CRP connection</li> <li>⓷ Terminal board associated with the RSE_2 connector for CRP connection, IO 485 card or Modbus RTU interface</li> <li>⓸ Connector for plug-in radio frequency card (AF)</li> <li>⓹ Terminal board for connecting the antenna</li> </ul> |
|--|--|

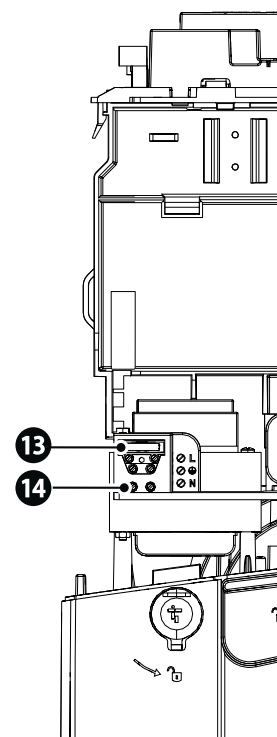
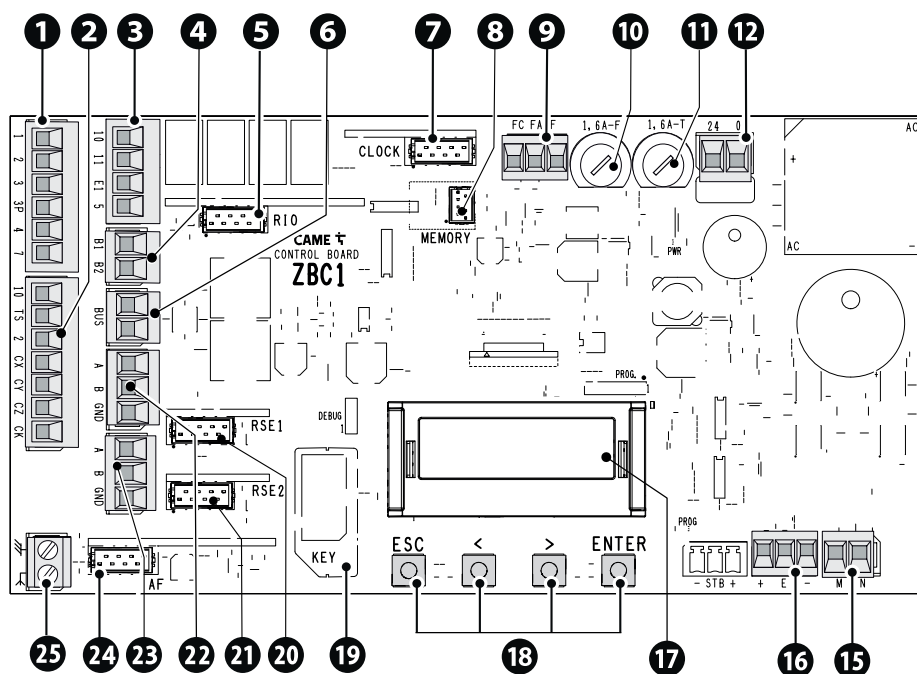

Remove the card cover before inserting the cards into the connectors.

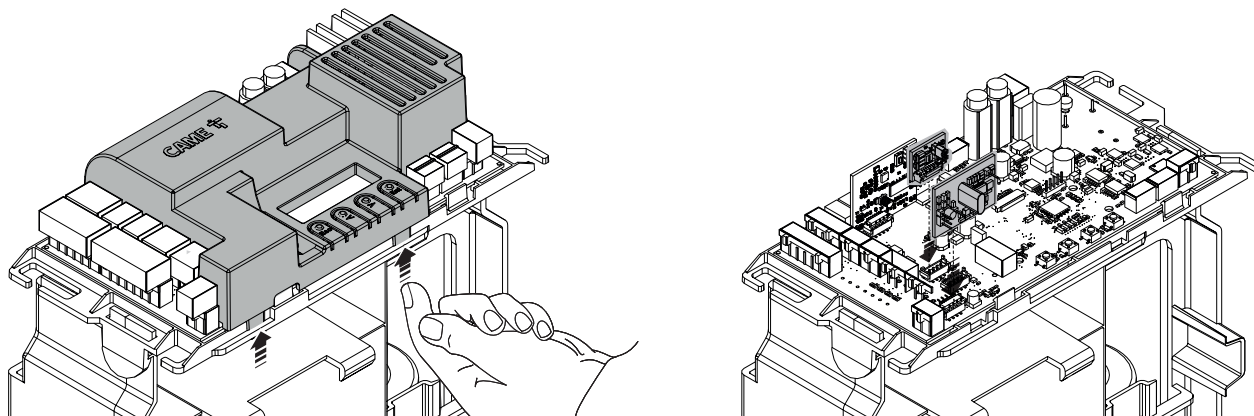

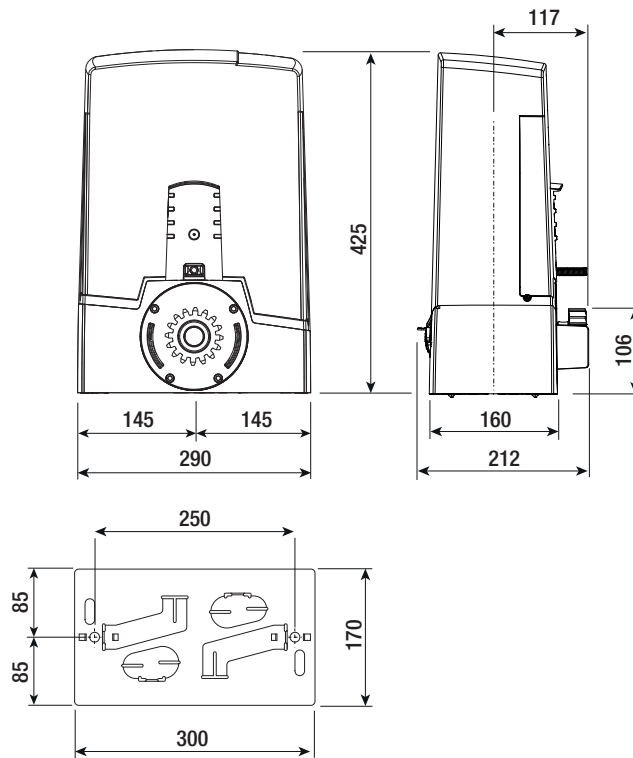

### Usage limitations

MODELS	BXV04AGE	BXV06AGE	BXV10AGE	BXV04AGM	BXV06AGM	BXV10AGM
Maximum gate-leaf length (m)	14	18	20	14	18	20
Maximum gate-leaf weight (kg)	400	600	1000	400	600	1000

### Fuse table

MODELS	BXV04AGE	BXV06AGE	BXV10AGE	BXV04AGM	BXV06AGM	BXV10AGM
Line fuse	1.6 A-F	1.6 A-F	1.6 A-F	1.6 A-F	1.6 A-F	1.6 A-F
Control-board fuse	1.6 A-T	1.6 A-T	1.6 A-T	1.6 A-T	1.6 A-T	1.6 A-T
Accessory fuse	1.6 A-F	1.6 A-F	1.6 A-F	1.6 A-F	1.6 A-F	1.6 A-F



## Technical data

MODELS	BXV04AGE	BXV06AGE	BXV10AGE	BXV04AGM	BXV06AGM	BXV10AGM
Power supply (V - 50/60 Hz)	230 AC	230 AC	230 AC	230 AC	230 AC	230 AC
Motor power supply (V)	24 DC	24 DC	24 DC	24 DC	24 DC	24 DC
Standby consumption (W)	5,5	5,5	5,5	5,5	5,5	5,5
Power (W)	170	270	400	170	270	400
Transformer thermal protection (°C)	120	120	120	120	120	120
Maximum current draw (A)	7	11	16	7	11	16
Colour	RAL 7024	RAL 7024	RAL 7024	RAL 7024	RAL 7024	RAL 7024
Operating temperature (°C)	-20 ÷ +55	-20 ÷ +55	-20 ÷ +55	-20 ÷ +55	-20 ÷ +55	-20 ÷ +55
Storage temperature (°C)*	-20 ÷ +70	-20 ÷ +70	-20 ÷ +70	-20 ÷ +70	-20 ÷ +70	-20 ÷ +70
Thrust (N)	350	600	1000	350	600	1000
Maximum operating speed (m/min)	12	12	11	12	12	11
Cycles/hour	CONTINUOUS OPERATION	CONTINUOUS OPERATION	CONTINUOUS OPERATION	CONTINUOUS OPERATION	CONTINUOUS OPERATION	CONTINUOUS OPERATION
Sound pressure level (dB A)	≤70	≤70	≤70	≤70	≤70	≤70
Control board	ZBC1	ZBC1	ZBC1	ZBC1	ZBC1	ZBC1
Pinion module	4	4	4	4	4	4
Reduction ratio	50	50	40	50	50	40
Limit-switch type	MECHANICAL	MECHANICAL	MECHANICAL	MAGNETIC	MAGNETIC	MAGNETIC
Protection rating (IP)	54	54	54	54	54	54
Insulation class	I	I	I	I	I	I
Weight (kg)	10	10	10	10	10	10
Average life (cycles)**	150000	150000	150000	150000	150000	150000

(\*) Before installing the product, keep it at room temperature where it has previously been stored or transported at a very high or very low temperature.

(\*\*) The average product life specified should be understood purely as an indicative estimate. It applies to normal usage conditions and where the product has been installed and maintained in compliance with the instructions provided in the CAME technical manual. The average product life is also affected, including significantly, by other variables such as, but not limited to, climatic and environmental conditions. The average product life should not be confused with the product warranty.

## Cable types and minimum thicknesses

Cable length (m)	up to 20	from 20 to 30
Power supply 230 V AC	3G x 1.5 mm <sup>2</sup>	3G x 2.5 mm <sup>2</sup>
24 V AC/DC flashing beacon	2 x 1 mm <sup>2</sup>	2 x 1 mm <sup>2</sup>
TX Photocells	2 x 0.5 mm <sup>2</sup>	2 x 0.5 mm <sup>2</sup>
RX photocells	4 x 0.5 mm <sup>2</sup>	4 x 0.5 mm <sup>2</sup>
Command and control devices	* no. x 0.5 mm <sup>2</sup>	* no. x 0.5 mm <sup>2</sup>

\* no. = see product assembly instructions - Warning: the cable cross-section is indicative and varies according to the motor power and cable length.

 When operating at 230 V and outdoors, use H05RN-F cables compliant with 60245 IEC 57 (IEC); when indoors, use H05VV-F cables compliant with 60227 IEC 53 (IEC). For power supplies up to 48 V, use FROR 20-22 II cables compliant with standard EN 50267-2-1 (CEI).

 To connect the antenna, use RG58 cable (up to 5 m).

 For paired connection and CRP, use UTP CAT5 cable (up to 1,000 m).

 If the cable lengths differ from those specified in the table, define the cable cross-sections according to the actual power draw of the connected devices and in line with regulation CEI EN 60204-1.

 For multiple, sequential loads along the same line, recalculate the values in the table according to the actual power draw and distances. For information on connecting products not covered in this manual, please see the documentation accompanying the products themselves.

### BUS cable table

 We recommend using a FROR 2x1mm<sup>2</sup> cable, maximum length from the control board: 50 m.

Single branch length (m)	max. 50 m
BUS cable	2 x 1 mm <sup>2</sup>

 The total length of all branches can be a maximum of 150 m.

 The cable cannot be shielded.

## INSTALLATION

 The following illustrations are examples only. The space available for fitting the operator and accessories varies depending on the area where it is installed. It is up to the installer to find the most suitable solution.

 The drawings show an operator fitted on the left.

### Preliminary operations

Dig a hole for the foundation frame.

Set up the corrugated tubes needed for the wiring coming out of the junction pit.

 Use  $\varnothing$  40 mm corrugated tubes to connect the gearmotor to the accessories.

 Prepare a  $\varnothing$  20 mm tube to run the release cord through. **A**

 The number of tubes depends on the type of system and the accessories that are going to be fitted.

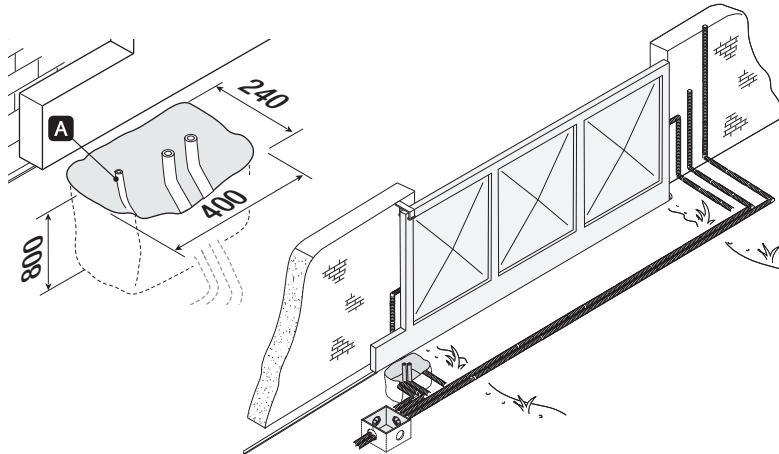

### Laying the anchoring plate

Set up a foundation frame that is larger than the anchoring plate.

Insert the foundation frame into the dug hole.

 The foundation frame must protrude by 50 mm, above ground level.

Fit an iron cage in the foundation frame to reinforce the concrete.

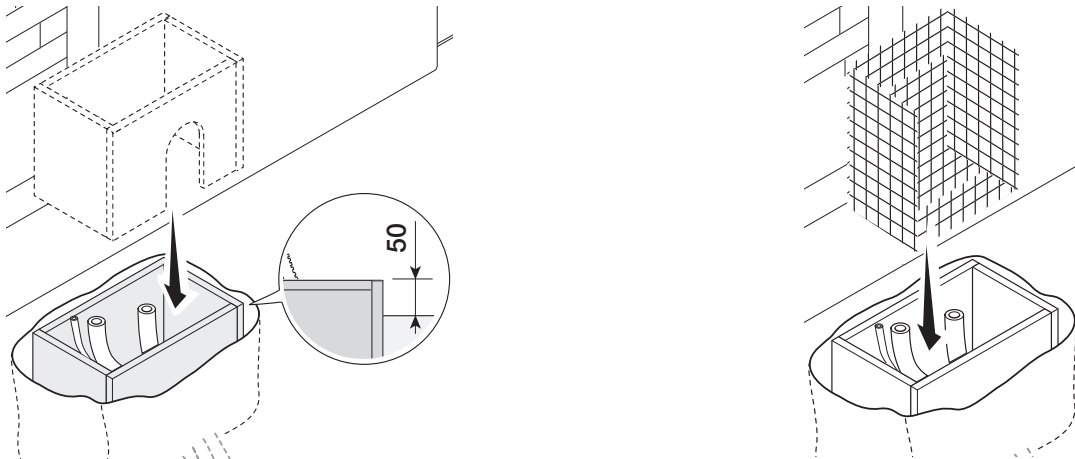

Insert the screws supplied in the anchoring plate.  
 Lock the screws in place with the nuts supplied.  
 Remove the pre-shaped clamps using a screwdriver.  
 Fit the anchoring plate in the iron cage.

The tubes must pass through the existing holes.

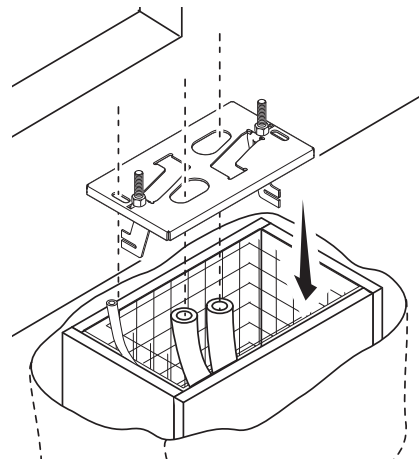
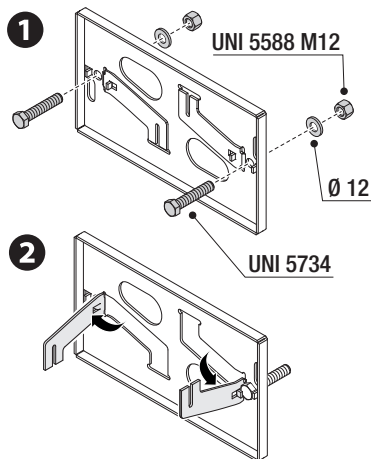

Position the anchoring plate, taking note of the measurements shown in the drawing.

If the gate does not have a rack, proceed with the installation.

See the section "FASTENING THE RACK".

Cast cement into the foundation frame.

The plate must be perfectly level and the screw threads completely above surface.

Wait at least 24 hours for the cement to dry.

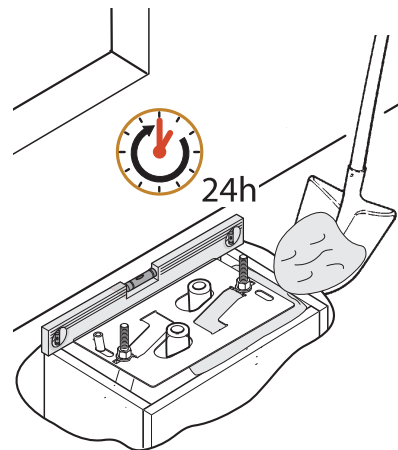
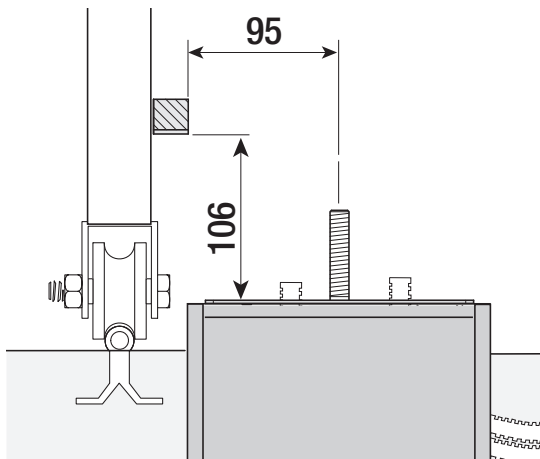

Remove the foundation frame.

Fill the hole with soil around the concrete block.

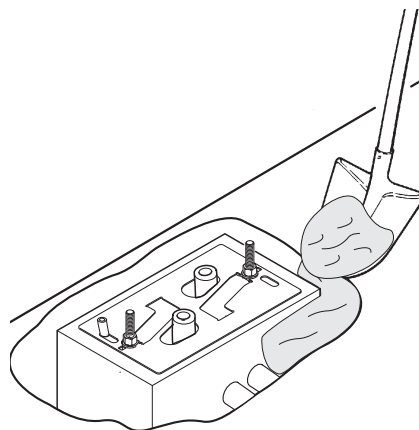
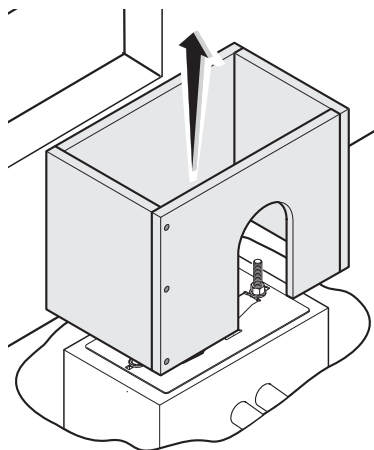

Remove the nuts from the screws.  
 Insert the electrical cables into the tubes until they protrude by about 600 mm.

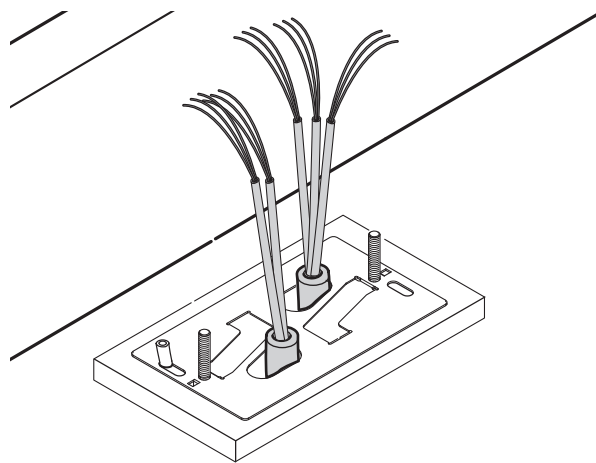
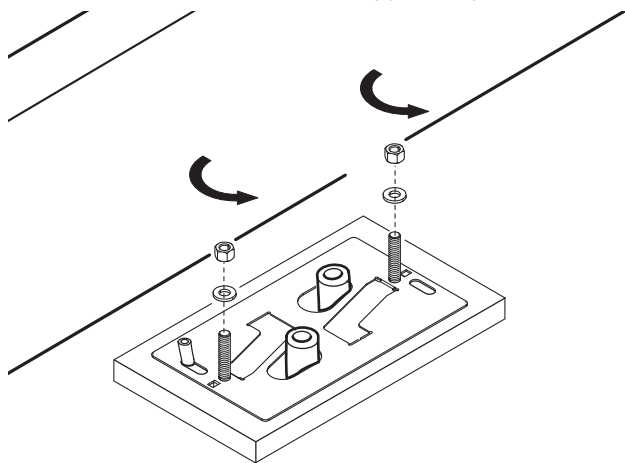

## Setting up the operator

Remove the operator cover.  
 Place the operator on top of the anchoring plate.

The electrical cables must pass under the operator foundation frame

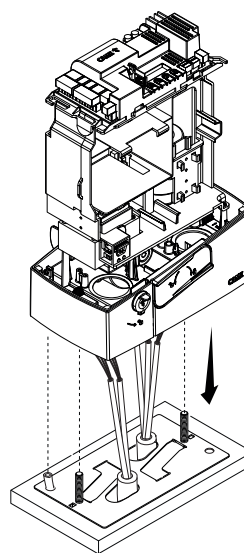
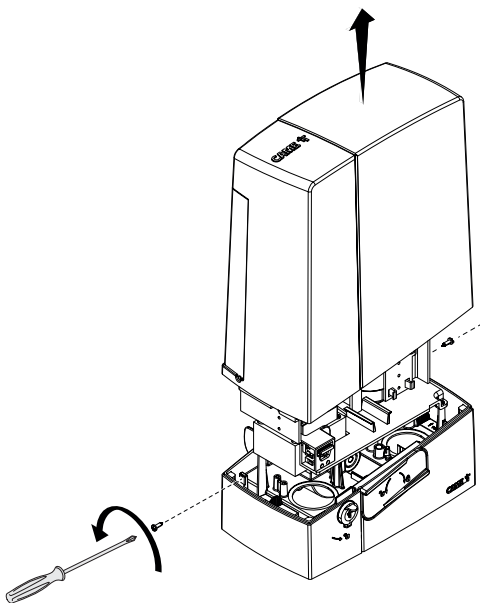

Make a hole in the cable gland.  
 Thread the cables through the cable gland.

Lift the operator by 5-10 mm from the plate by adjusting the threaded feet, to allow for any adjustments that may need to be made between the rack and pinion.

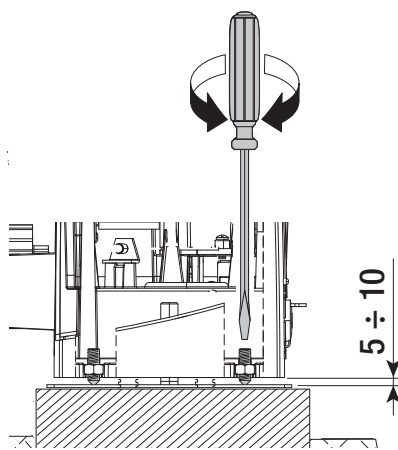
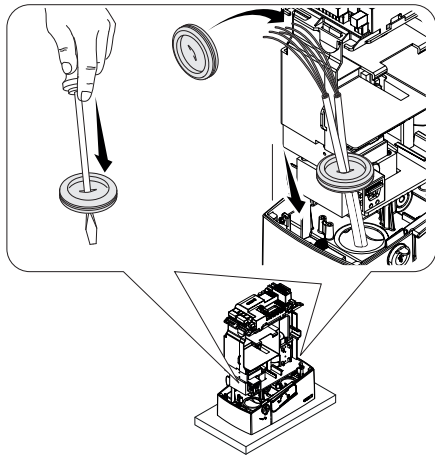

## Fastening the rack

- 1 Release the operator.
- 2 Rest the rack on the pinion.
- 3 Weld or fasten the rack to the gate along its entire length.

 To assemble the rack modules, use an extra piece and rest it under the join, then fasten it in place using two clamps.

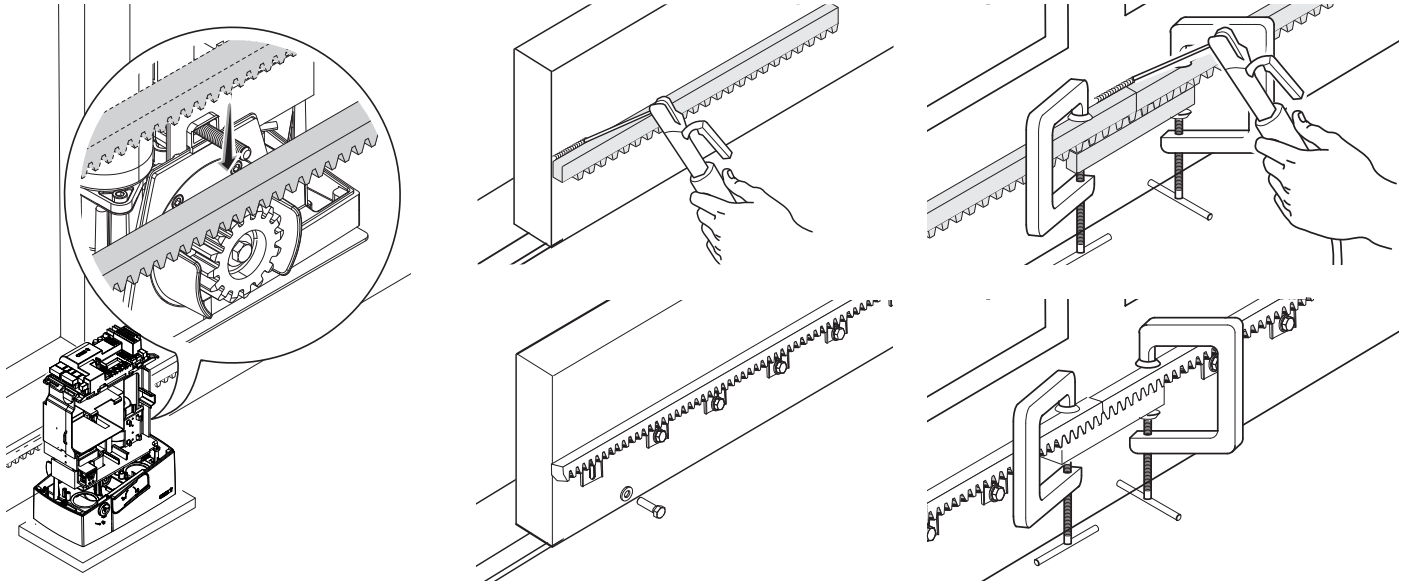

## Adjusting the pinion-rack coupling

Open and close the gate manually.

Adjust the pinion-rack coupling distance using the threaded feet (vertical adjustment) and the holes (horizontal adjustment).

 The weight of the gate must not bear down upon the operator.

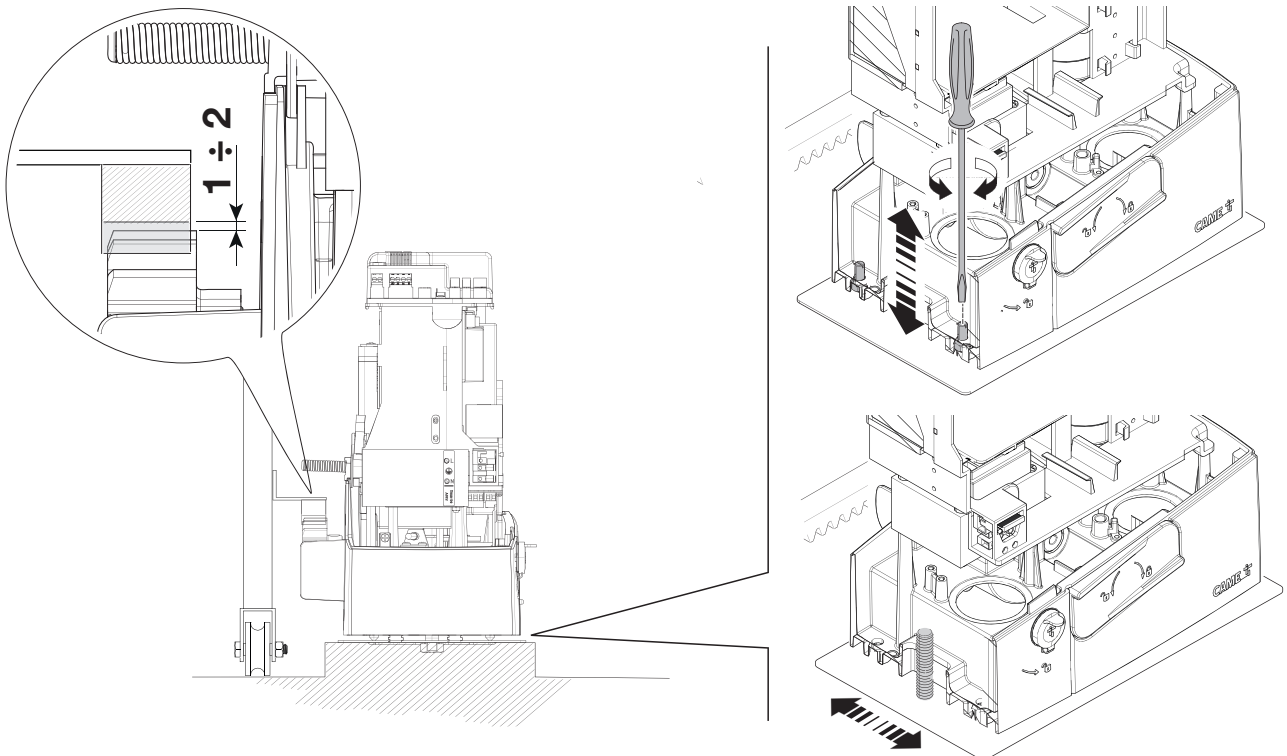

## Fastening the operator in place

 Only fasten the operator after adjusting the pinion-rack coupling.  
Fasten the operator to the anchoring plate using stoppers and nuts.

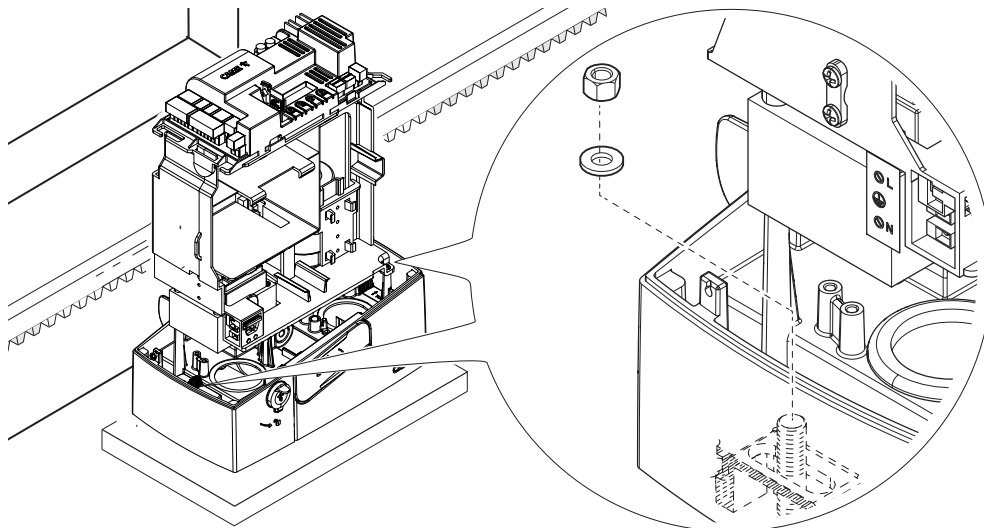

## Determining the travel end points with mechanical limit switches (BXV04AGE - BXV06AGE - BXV10AGE)

- 1 Open the gate.
- 2 Insert the opening limit-switch tab in the rack.  
The spring must trigger the microswitch.
- 3 Fasten the opening limit-switch tab using the grub screws supplied.

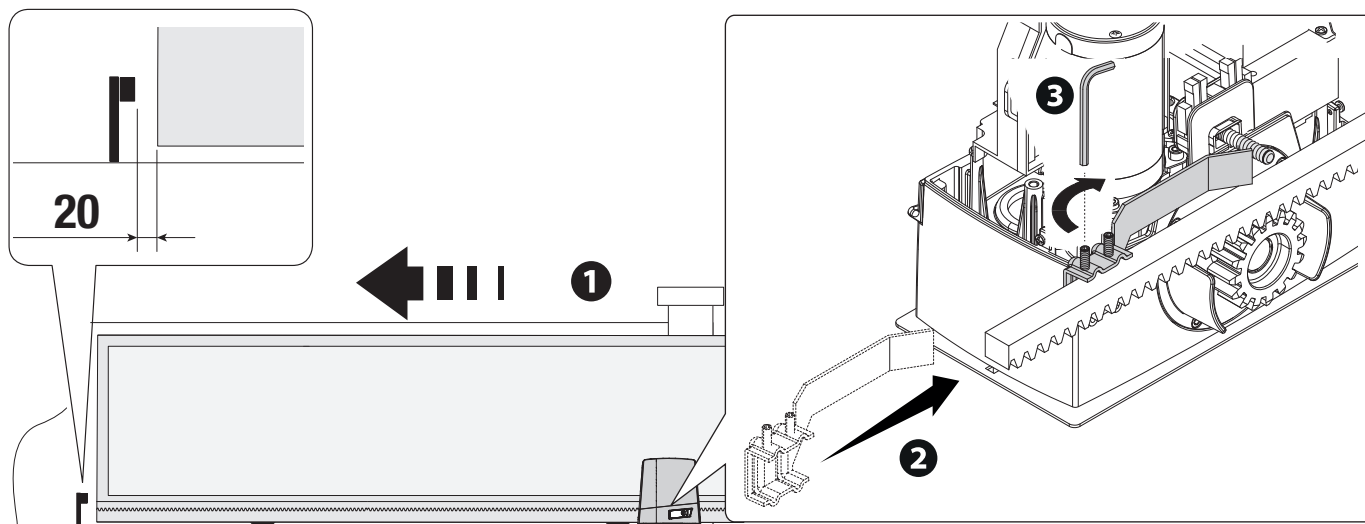

- 4 Close the gate.
- 5 Insert the closing limit-switch tab in the rack.
- The spring must trigger the microswitch.
- 6 Fasten the closing limit-switch tab using the grub screws supplied.

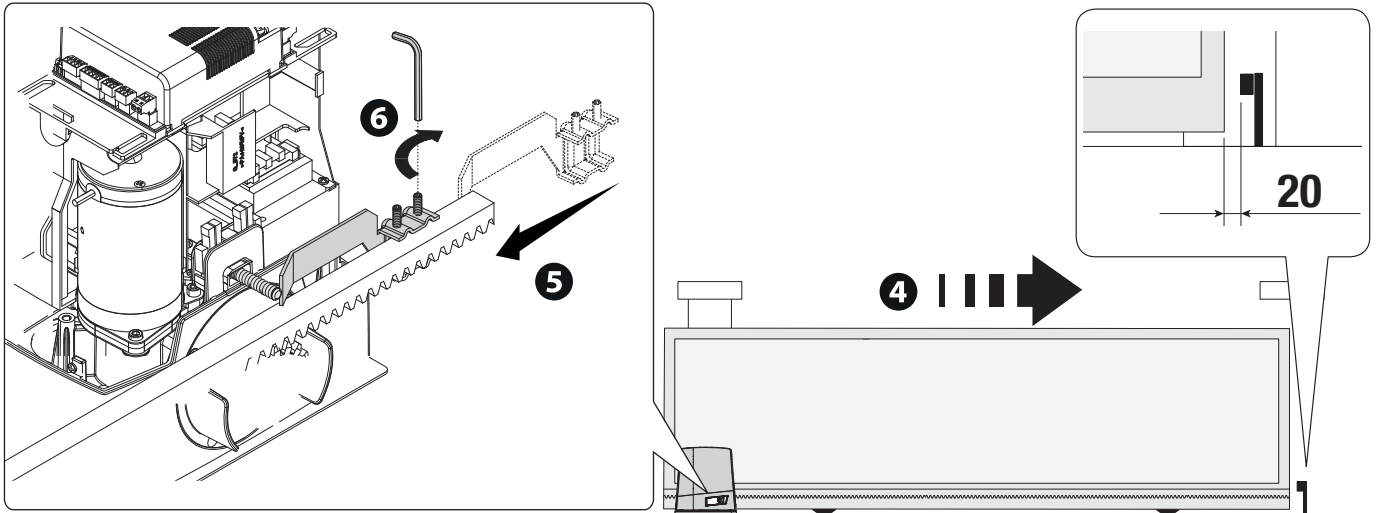

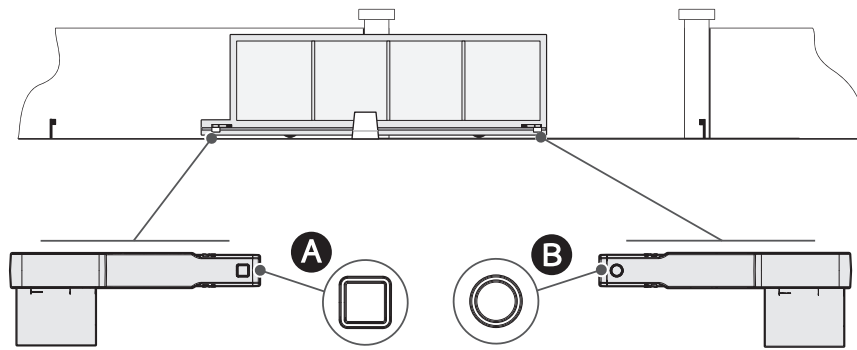

### Establishing the travel end points with magnetic limit switches (BXV04AGM - BXV06AGM - BXV10AGM)

- A Magnetic limit-switch tab during closing
- B Magnetic limit-switch tab during opening

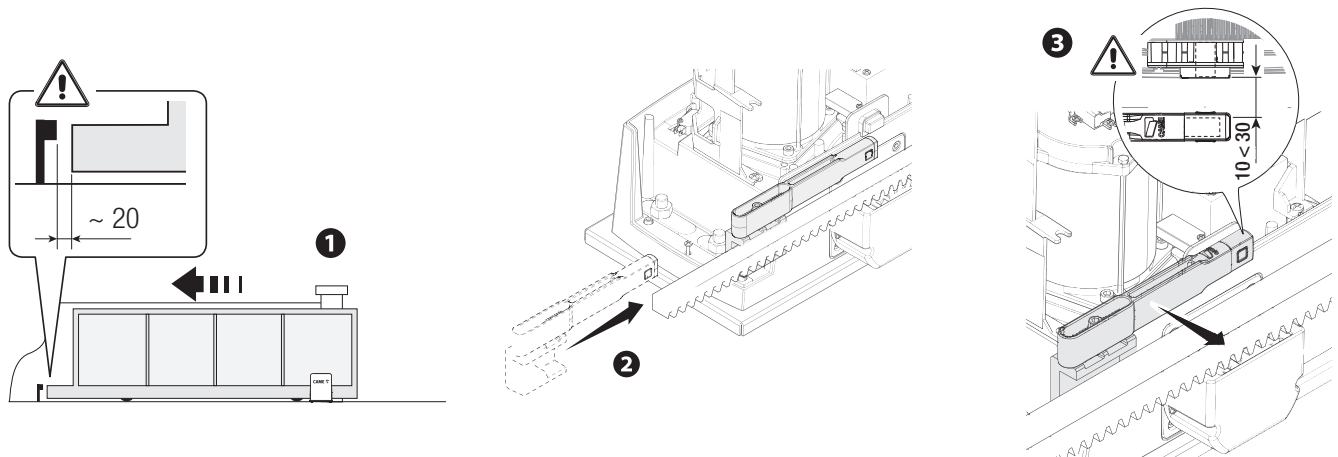

- 1 Open the gate.
- 2 Insert the magnetic opening limit-switch tab on the rack.
- 3 The tab magnet must be between 10 and 30 mm from the magnetic sensor.



- 4 Fasten the support to the rack using the grub screws supplied.
- 5  The limit-switch tab magnet must be perpendicular to the magnetic sensor.
- 6 Fasten the limit-switch tab using the screw (supplied).

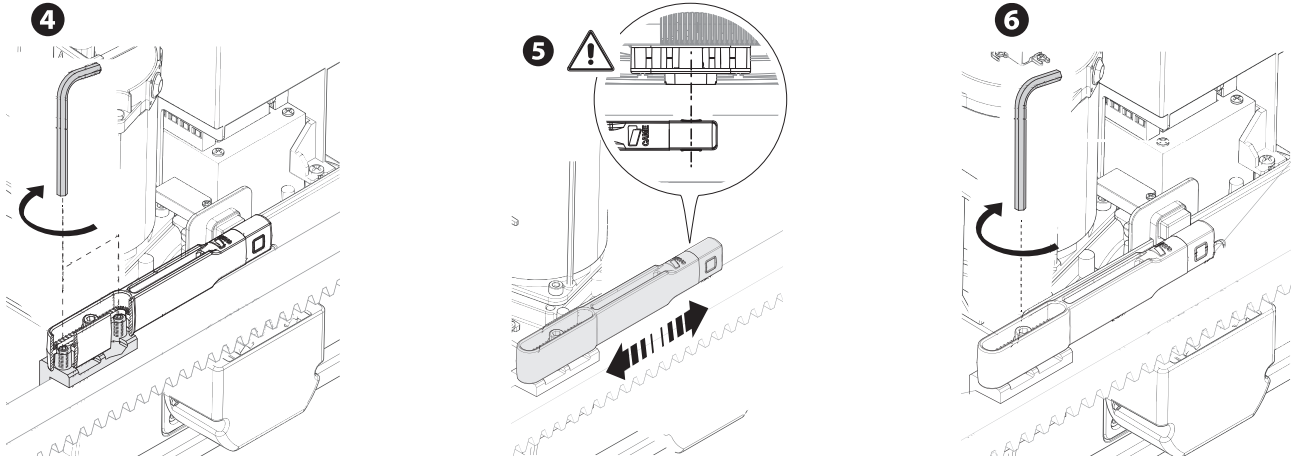

- 1 Close the gate.
- 2 Insert the magnetic closing limit-switch tab on the rack.
- 3  The tab magnet must be between 10 and 30 mm from the magnetic sensor.

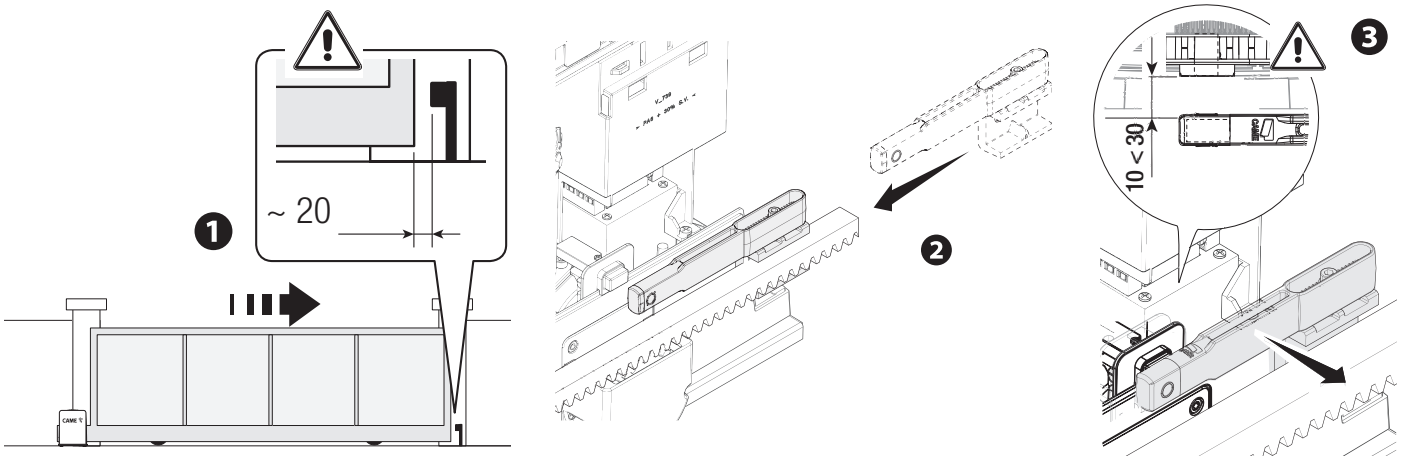

- 4 Fasten the support to the rack using the grub screws supplied.
- 5  The limit-switch tab magnet must be perpendicular to the magnetic sensor.
- 6 Fasten the limit-switch tab using the screw (supplied).

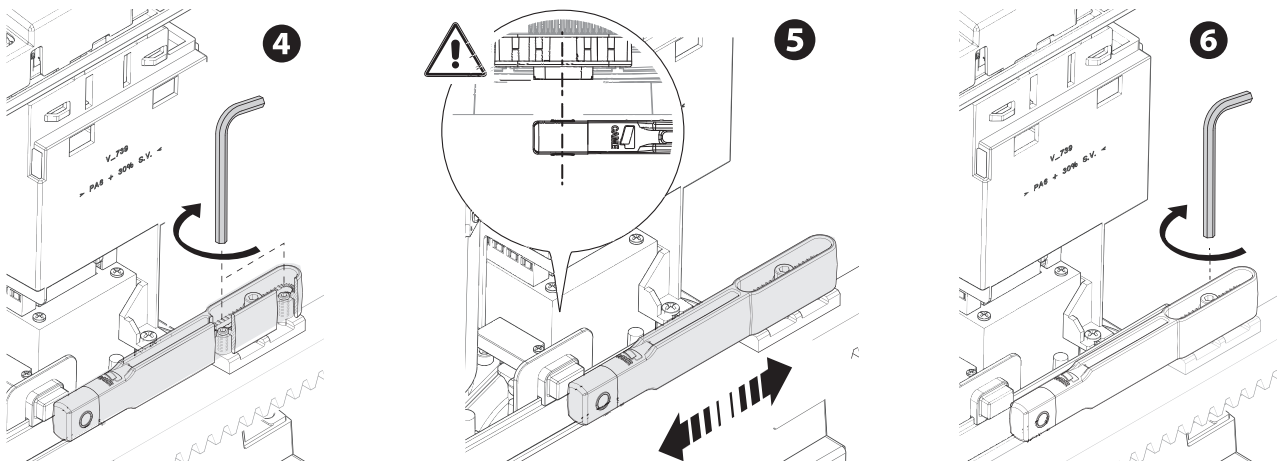



**Passing the electrical cables**

📖 Connect all wires and cables in compliance with the law.

The electrical cables must not touch any parts that may overheat during use (such as the motor and transformer).

📖 Use membrane cable glands to connect the devices to the control panel. One of these must be intended exclusively for the power supply cable.

⚠️ Thread the cables through the holes in the control board holder (A). The cables need to sit perfectly flush to the side of the operator as shown below to ensure the cover closes. Use cable ties or insulating tape if necessary.

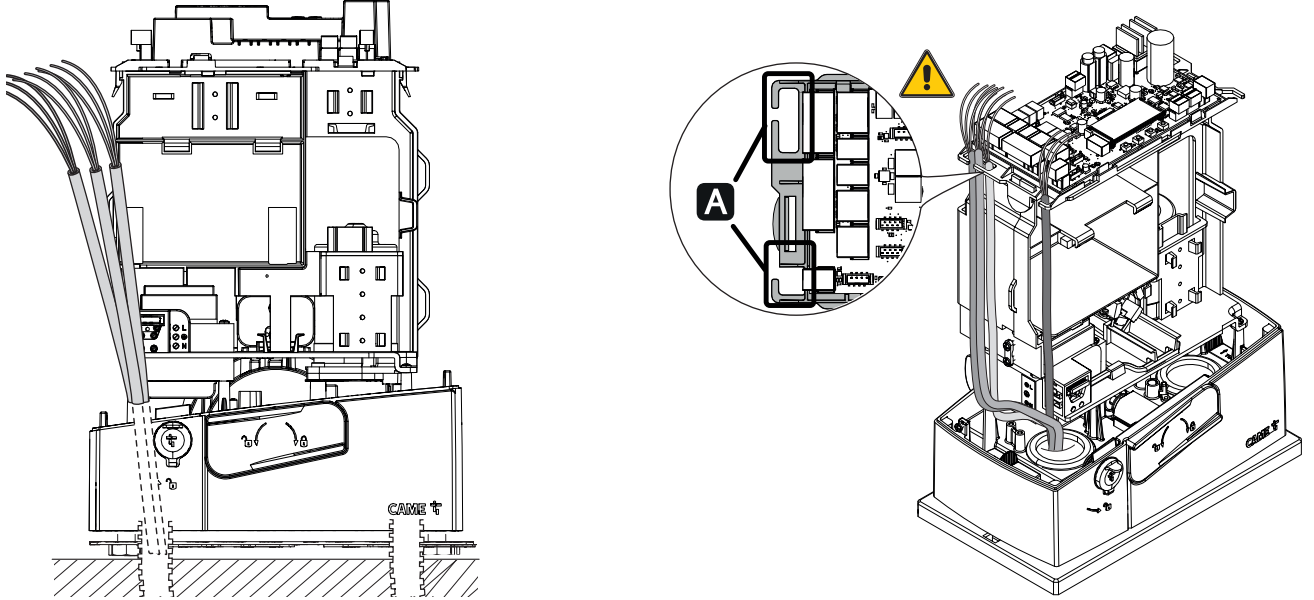

**Power supply**

Make sure the mains power supply is disconnected during all installation procedures.

⚠️ Before working on the control panel, disconnect the mains power supply and remove the batteries, if any.

**Connecting to the mains (230 V AC - 50/60 Hz)**

- ⓕ Line fuse
- Ⓛ Phase
- Ⓝ Neutral
- Ⓧ Earth

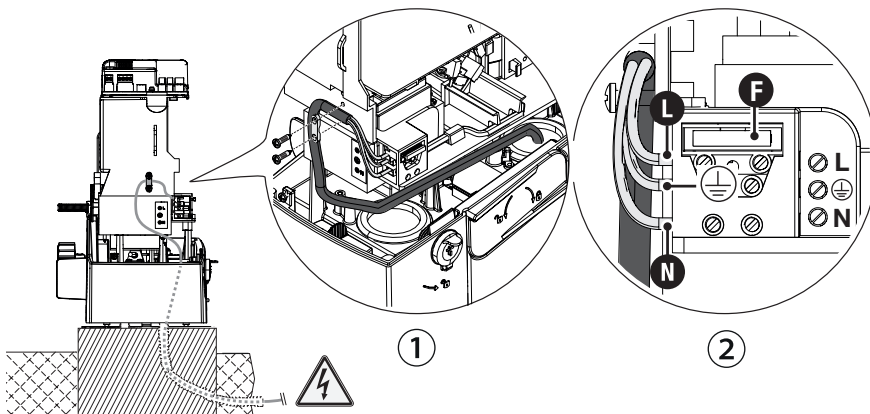

**Power supply output for accessories**

The output normally delivers 24 V AC.

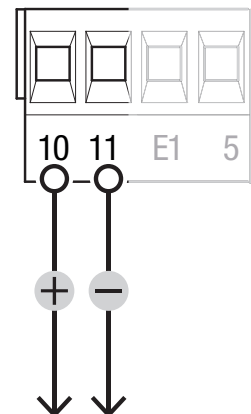

## Maximum capacity of contacts

The total power of the outputs listed below must not exceed the maximum output power [Accessories]

Device	Output	Power supply (V)	Maximum power (W)
Accessories	10 - 11	24 AC	40
Light E1	10 - E1	24 AC	25
Passage-open warning light	10 - 5	24 AC	3

The outputs deliver 24 V DC when the batteries start operating, if they are installed.

Device	Output	Power supply (V)	Power (W)
Auxiliary contact	B1 - B2	-	24 (24V AC/DC)
BUS CXN	BUS	15 DC	15

Do not connect anything other than CAME BUS accessories.

## Devices with BUS CXN system

The CXN CAME system is a two-wire non-polarised communication BUS which allows you to connect up all compatible CAME devices.

Connection to the BUS can be in a chain, star or mixed formation.

Once the system has been wired, and after having set the address on each device, the function of each accessory can be configured on the control panel. This method allows you to configure the set-up immediately without having to do so later and intervene directly on the accessories and system wiring.

The CXN BUS can support control devices, interfaces, photocells, safety devices, beacons and gateways at the same time.

### Cabling

- ❶ Chain connection
- ❷ Star connection
- ❸ Mixed connection

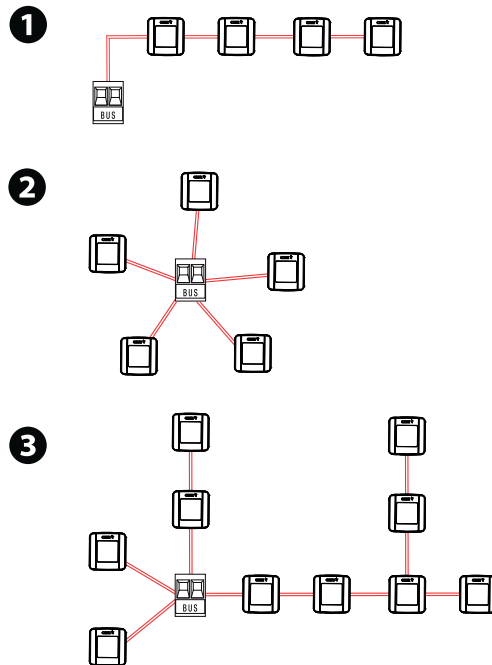

### Cable type

We recommend using a FROR 2x1mm<sup>2</sup> cable, maximum length from the control board: 50 m.

Single branch length (m)	max. 50 m
BUS cable	2 x 1 mm <sup>2</sup>

The total length of all branches can be a maximum of 150 m.

The cable cannot be shielded.

## Maximum number of devices that can be connected, by type

Type of device	Maximum number of devices per type
Selectors	7
Photocell pairs	8
Interfaces	2
Flashing beacons	2

## BUS CXN device consumption



Scan the QR code to access an interactive table showing consumption data, and calculate the maximum number of BUS devices you can connect to the control panel.

BUS CXN device consumption is calculated in CXN units.

## Command and control devices

### 1 STOP button (NC contact)

This stops the operator and excludes automatic closing. Use a control device to resume movement.

When the contact is being used, it must be activated during programming.

### 2 Control device (NO contact)

Open command

When the [Hold-to-run] function is active, a control device must be set to OPEN.

### 3 Control device (NO contact)

Partial Opening command

See [Adjusting partial opening] function.

### 4 Control device (NO contact)

Close command

When the [Hold-to-run] function is active, a control device must be set to CLOSE.

### 5 Control device (NO contact)

Step-by-step command

Sequential command

See control [Function 2-7].

### 6 Antenna with RG58 cable

If the chosen signalling device can be fitted with an antenna, use the terminal shown to connect it.

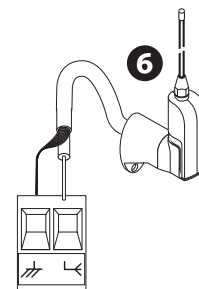
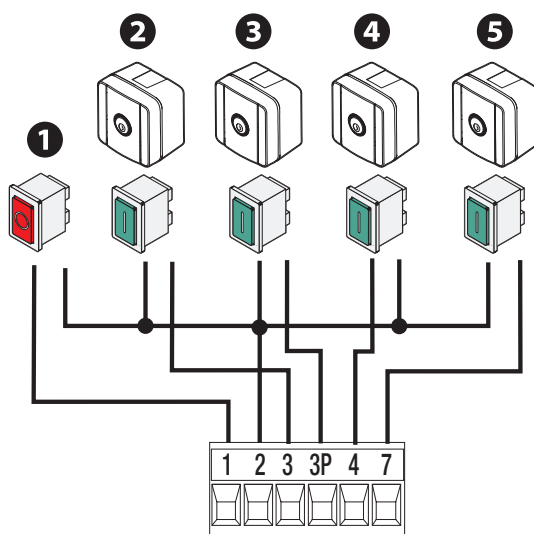

## Signalling devices

### 1 Additional light

It increases the light in the manoeuvring area.

### 2 Flashing beacon

It flashes when the operator opens and closes.

### 3 Passage-open warning light

It notifies the user of the operator status.

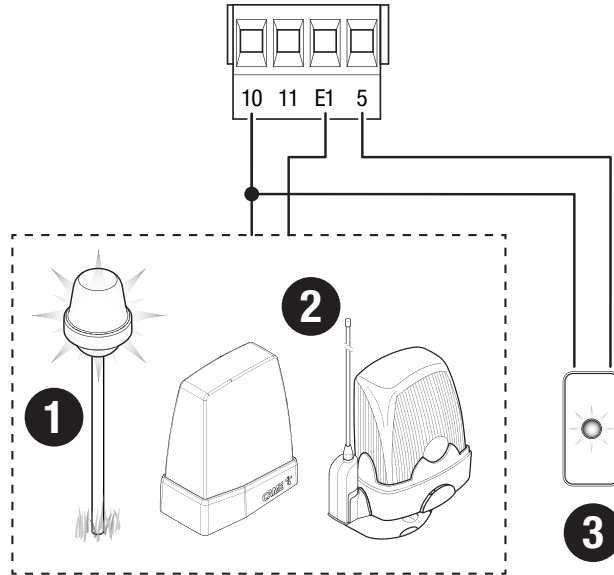

## Safety devices

During programming, configure the type of action that must be performed by the device connected to the input. Connect the safety devices to the CX and/or CY and/or CZ and/or CK inputs.

If used, the contacts C1 CX CY CZ CK must be configured during programming.

For systems with multiple pairs of photocells, please see the manual for the relevant accessory.

### DELTA photocells

Standard connection

### DELTA photocells

Connection with safety test

See [Safety devices test] function.

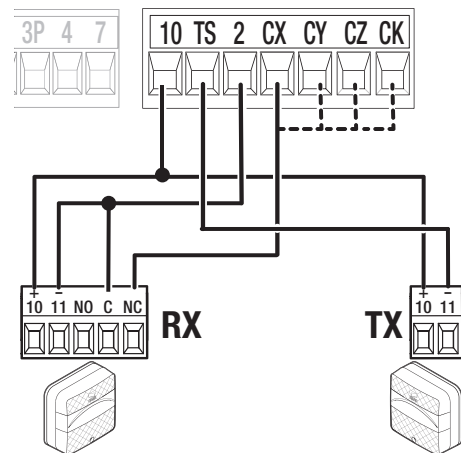
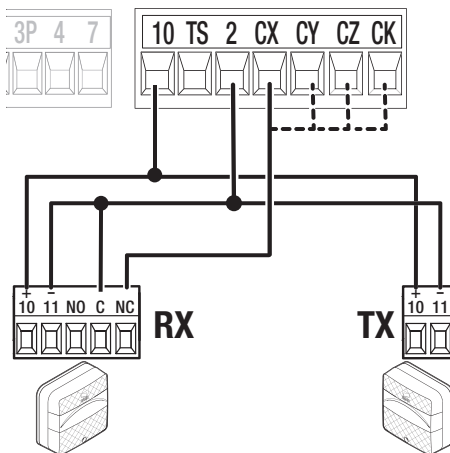

### DIR / DELTA-S photocells

Standard connection

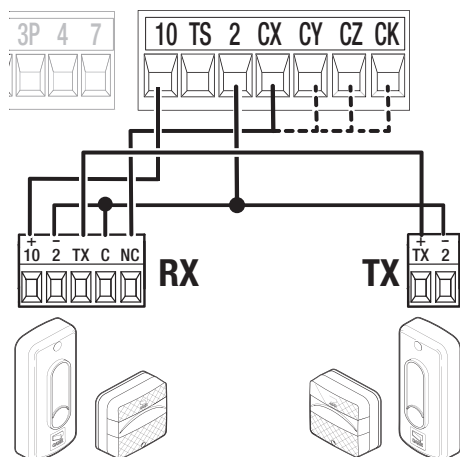

### DIR / DELTA-S photocells

Connection with safety test

See [Safety devices test] function.

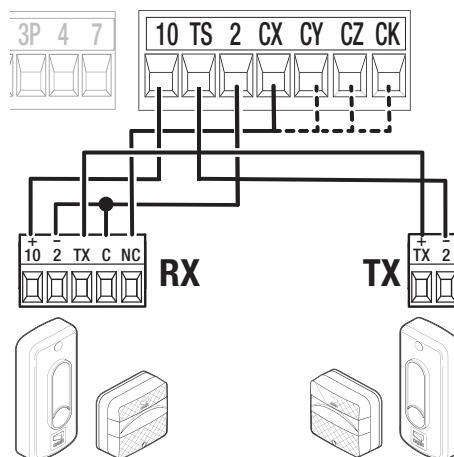

### DXR - DLX photocells

Standard connection

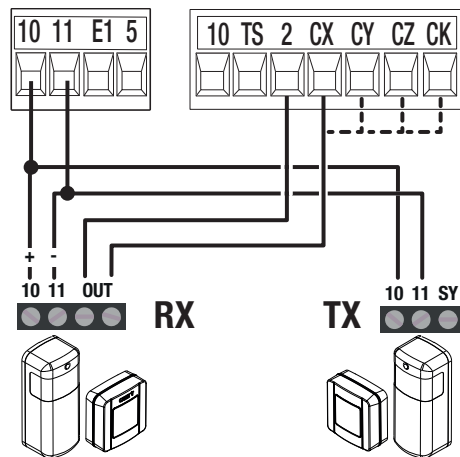

### DXR - DLX photocells

Connection with safety test

See [Safety devices test] function.

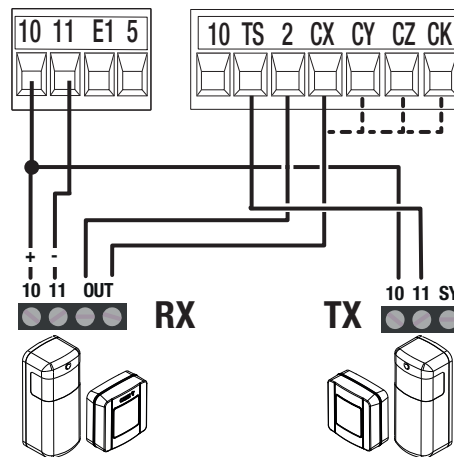

### DFWN sensitive edge

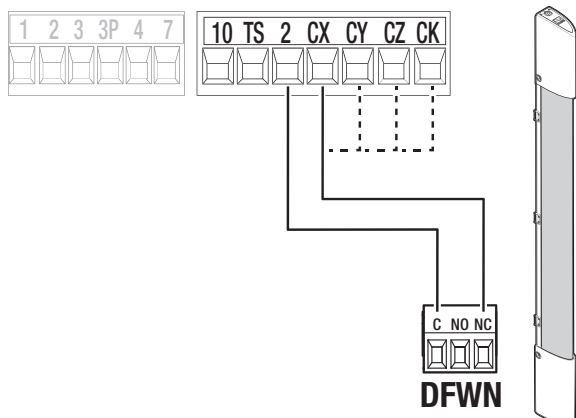

Programming button functions

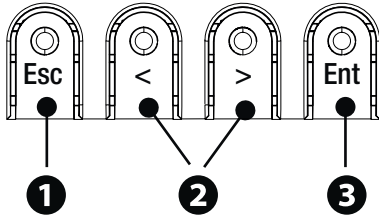

**1 ESC button**

- The ESC button is used to perform the operations described below.
- Exit the menu
- Delete the changes
- Go back to the previous screen
- Stop the operator

**2 <> buttons**

- The <> buttons are used to perform the operations described below.
- Navigate the menu
- Increase or decrease values
- Open or close the operator

**3 ENTER button**

- The ENTER button is used to perform the operations described below.
- Access menus
- Confirm choice

Getting started

Once the electrical connections have been made, proceed with commissioning. Only skilled and qualified staff may perform this operation. Make sure that there are no obstacles in the way. Power up the device and follow the instructions on the display. Start programming following the wizard.

If this is not the first time the board is being switched on, go to the menu Configuration > Wizard. Follow the indications shown on the display.

Complete programming and check the warning, safety and protection devices, and the manual release, are working properly.

After powering up the system, the first manoeuvre is always to open the gate Wait for the manoeuvre to be completed.

Press the ESC button or STOP button immediately in the event of any faults, malfunctions, strange noises or vibrations, or unexpected behaviour in the system.

Perform the first manoeuvre where you can see the gate in motion and with the photocells active, including where remotely controlled.

If CALIBRATION REQUIRED appears on the display, you must calibrate the travel. The panel will not accept motion commands, except for the motor test.

Functions menu

Menu layout

Some options only show on the display if certain conditions are met. For more information, please see the information for the individual functions.

Level 1	Level 2	Level 3	Level 4
Configuration	Motor settings	Opening direction	
		Encoder	
		Motor test	
		Travel calibration	
		Motor type	

Gate travel settings	Opening speed		
	Closing speed		
	Opening slowdown speed		
	Closing slowdown speed		
	Travel AST control		
	Slowdown AST control		
	Soft start		
	Part. open point		
	Opening slowdown point		
	Closing slowdown point		
	Impact test		
Wired safety devices	Total stop		
	CX input		
	CY input		
	CZ input		
	CK input		
	Safety devices test		
	Obst. with motor stopped		
RIO safety devices	RIO ED T1		
	RIO ED T2		
	RIO PH T1		
	RIO PH T2		
BUS Devices	BUS Photocell 1		
	Photocell BUS 2		
	Photocell BUS 3		
	Photocell BUS 4		
	Photocell BUS 5		
	Photocell BUS 6		
	Photocell BUS 7		
	Photocell BUS 8		
	BUS 1 key selector		Key to the right
			Key to the left
	BUS 2 key selector		Key to the right
			Key to the left
	BUS 3 key selector		Key to the right
			Key to the left

	BUS 4 key selector	Key to the right
		Key to the left
	BUS 5 key selector	Key to the right
		Key to the left
	BUS 6 key selector	Key to the right
		Key to the left
	BUS 7 key selector	Key to the right
		Key to the left
	I/O module BUS 1	input I1
		input I2
		Light output
		Relay output
	I/O module BUS 2	input I1
		input I2
		Light output
		Relay output
	BUS flashing beacon	Opening colour
		Closing colour
		Auto. cl. colour
		Pre-flashing colour
Signal error		
	BUS device lights	Signal maintenance
Command inputs	Command 2-7	
Functions	Hold-to-run	
	B1-B2 output	
	Removing obstacles	
Times	Automatic close	
	Automatic partial close	
Manage lights	Passage-open warning light	
	Light E1	
	Courtesy time	
	Pre-flashing time	
RSE communication	RSE1	
	CRP address	
	RSE1 speed	
	RSE2 speed	
External memory	Save data	
	Read data	



	Parameter reset		
	Guided procedure (Wizard)		
Manage users	New user		
	Remove user		
	Remove all		
	Radio decoding		
	Rolling self-learning		
	Change mode		
Information	FW version		
	BUS device status		
	Manoeuvre counter		
	Maintenance conf.		
	Maintenance reset		
	Errors list		
Timer management	Show clock		
	Set the clock		
	Automatic DST		
	Time format		
	Create new timer	Open	Start time
			End time
			Days of the week
	Partial opening		Start time
			End time
			Days of the week
B1-B2 output		Start time	
		End time	
		Days of the week	
Remove timer			
Language			
Password	Enable password		
	Remove password		
	Change password		

## List of functions

### Opening direction

Set gate-opening direction.

<b>Configuration &gt;</b>	<b>Opening direction</b>	To the left (Default) To the right
<b>Motor settings</b>		

### Encoder

Use the encoder input from the motor.

<b>Configuration &gt;</b>	<b>Encoder</b>	Activated (Default) Off
<b>Motor settings</b>		

### Motor test

Check correct gate-leaf opening direction.

 If the buttons do not execute the commands correctly, invert the gate-opening direction using the [Opening direction] function.

 The gate will move at reduced speed.

<b>Configuration &gt;</b>	<b>Motor test</b>	The > button moves the gate to the right The < button moves the gate to the left
<b>Motor settings</b>		

### Travel calibration

Start the travel self-learning.

<b>Configuration &gt;</b>	<b>Travel calibration</b>	
<b>Motor settings</b>		

### Motor type

Set the type of gearmotor installed.

<b>Configuration &gt;</b>	<b>Motor type</b>	BXV04 BXV06 BXV10
<b>Motor settings</b>		

### Opening speed

Set the opening speed (percentage of maximum speed).

<b>Configuration &gt;</b>	<b>Opening speed</b>	30% to 100% (Default 100%)
<b>Gate travel settings</b>		

### Closing speed

Set the closing speed (percentage of maximum speed).

<b>Configuration &gt;</b>	<b>Closing speed</b>	30% to 100% (Default 100%)
<b>Gate travel settings</b>		

### Opening slowdown speed

Set the slowdown speed during opening (as a percentage of the maximum speed).

 The parameter is only used with the [Opening slowdown point] function active.

 If the slowdown speed is incorrectly set to a value higher than the opening speed by mistake, the parameter is corrected.

<b>Configuration &gt;</b>	<b>Opening slowdown speed</b>	5% to 60% (Default 50%)
<b>Gate travel settings</b>		

### Closing slowdown speed

Set the slowdown speed during closing (as a percentage of the maximum speed).

 The parameter is only used with the [Closing slowdown point] function active.

 If the slowdown speed is incorrectly set to a value higher than the closing speed by mistake, the parameter is corrected.

<b>Configuration &gt;</b>	<b>Closing slowdown speed</b>	5% to 60% (Default 50%)
<b>Gate travel settings</b>		

### Travel AST control



Adjust the obstruction detection sensitivity during the gate travel in percentage terms.

<b>Configuration &gt;</b>	<b>Travel AST control</b>	Deactivated (Default)  Maximum thrust and low obstruction sensitivity.  Minimum Average Maximum* *  Minimum thrust and high obstruction sensitivity.  Customised The personalised values to be used are expressed as a percentage: - from 10% (minimum thrust and high obstruction sensitivity) - to 100% (maximum thrust and low obstruction sensitivity)
<b>Gate travel settings</b>		

### Slowdown AST control

Adjust the obstruction detection sensitivity during slowdown in percentage terms.

 The parameter is only used if the opening or closing slowdown point is active.

<b>Configuration &gt;</b>	<b>Slowdown AST control</b>	Deactivated (Default)  Maximum thrust and low obstruction sensitivity.  Minimum Average Maximum* *  Minimum thrust and high obstruction sensitivity.  Customised The personalised values to be used are expressed as a percentage: - from 10% (minimum thrust and high obstruction sensitivity) - to 100% (maximum thrust and low obstruction sensitivity)
<b>Gate travel settings</b>		

### Soft start

Set a slowdown of a few seconds after each opening and closing command.

<b>Configuration &gt;</b>	<b>Soft start</b>	Deactivated (Default) On
<b>Gate travel settings</b>		

### Adjusting the partial opening

Set the gate's partial-opening percentage.

<b>Configuration &gt;</b>	<b>Part. open point</b>	10% to 100% (20% Default)
<b>Gate travel settings</b>		

### Opening slowdown point

Set the percentage of the total travel to be used for slowdown during gate opening.

 During travel calibration, the opening slowdown point is automatically set to allow for a slowing space of 60 cm.

Configuration > Gate travel settings	Opening slowdown point	2% to 60% (Default 25%)
---	------------------------	-------------------------

### Closing slowdown point

Set the percentage of the total travel to be used for slowdown during gate closing.

 During travel calibration, the closing slowdown point is automatically set to allow for a slowing space of 60 cm.

Configuration > Gate travel settings	Closing slowdown point	2% to 60% (Default 25%)
---	------------------------	-------------------------

### Impact test

Activate/deactivate test mode for impact tests. With the function on, the operator does not signal errors connected to obstacle detection after more than one consecutive impact.

Pre-set the travel parameters, according to the gate weight, to use for impact tests.

 Test mode is deactivated automatically after 1 hour.

 With the function on, the display shows the  icon.

Configuration > Gate travel settings	Impact test	Activate mode Deactivate mode Leaf weight  Only versions BXV04 and BXV06.  Select the gate weight value closest to the real weight: 200 (Default)/300/400 kg for BXV04 400 (Default)/500/600 kg for BXV06  Apply pre-set Configure the travel parameters according to the set leaf weight.
---	-------------	---

### Total stop

Activate or deactivate input 2-1. If it is activated, the input is used as a normally closed contact.

 If the input is active, this excludes all commands, including any automatic closing.

Configuration > Wired safety devices	Total stop	Deactivated (Default) On
---	------------	-----------------------------

### CX input, CY input, CZ input, CK input

Associate a function with the input CX CY CZ CK

<b>Configuration &gt;</b> <b>Wired safety devices</b>	<b>CX input</b> <b>CY input</b> <b>CZ input</b> <b>CK input</b>	Deactivated (Default) C1 = Reopen while closing (photocells) C2 = Reclose while opening (photocells) C3 = Partial stop Only with [Automatic close] activated. C4 = Obstacle standby (photocells) C7 = Reopen while closing (sensitive edges) C8 = Reclose while opening (sensitive edges) C13 = Reopen while closing, with immediate closure once the obstruction has been removed, even if the gate is not in motion r7 = Reopen while closing (sensitive edges with 8K2 resistor) r8 = Reclose while opening (sensitive edges with 8K2 resistor) r7 (two sensitive edges) = Reopen while closing (pair of sensitive edges with 8K2 resistor) r8 (two sensitive edges) = Reclose while opening (pair of sensitive edges with 8K2 resistor)
--	--	--

### Safety devices test

Check that the photocells connected to the selected inputs are operating correctly, after each opening and closing command.

 Run the test by connecting the photocells to the TS terminal [see paragraph on Safety devices].

<b>Configuration &gt;</b> <b>Wired safety devices</b>	<b>Safety devices test</b>	Deactivated (Default) CX ___ _CY _ CX CY _ _ _ CZ _ CX _ CZ _ _CY CZ _ CX CY CZ _ _ _ _ CK CX _ _ CK _CY _ CK CX CY _ CK _ _ CZ CK CX _ CZ CK _CY CZ CK CX CY CZ CK
--	----------------------------	--

### Obstacle with motor stopped

With the function active, the operator remains stopped if the safety devices detect an obstacle. The function is active when the gate is closed, open or after a complete stop.

<b>Configuration &gt;</b> <b>Wired safety devices</b>	<b>Obst. with motor stopped</b>	Disabled (Default) On
--	---------------------------------	--------------------------

### RIO ED T1 and RIO ED T2

Associate one of the available functions with a wireless safety device.

 The function only appears if the RIO CONN interface board is present.

<b>Configuration &gt;</b> <b>RIO safety devices</b>	<b>RIO ED T1</b> <b>RIO ED T2</b>	Deactivated (Default) P0 = It stops the gate and excludes automatic closing. Use a control device to resume movement. P7 = Reopen while closing. P8 = Reclose while opening.
--	--------------------------------------	---

## RIO PH T1 and RIO PH T2

Associate one of the available functions with a wireless safety device.

 The function only appears if the RIO CONN interface board is present.

<b>Configuration &gt;</b> <b>RIO safety devices</b>	<b>RIO PH T1</b> <b>RIO PH T2</b>	Deactivated (Default) P1 = Reopen while closing. P2 = Reclose while opening. P3 = Partial stop. Only with [Automatic close] activated. P4 = Obstacle standby. P13 = Reopening during closure with immediate stop once the obstacle has been removed, even with the gate not in motion.
--	--------------------------------------	---

## BUS photocells

Associate a function with the input for the BUS photocells.

 The function only appears if there is a BUS photocell connected.

<b>Configuration&gt;</b> <b>BUS Devices</b>	<b>BUS Photocell 1</b> <b>Photocell BUS 2</b> <b>Photocell BUS 3</b> <b>Photocell BUS 4</b> <b>Photocell BUS 5</b> <b>Photocell BUS 6</b> <b>Photocell BUS 7</b> <b>Photocell BUS 8</b>	Deactivated (Default) C1 = Reopen while closing (photocells) C2 = Reclose while opening (photocells) C3 = Partial stop Only with [Automatic close] activated. C4 = Obstacle standby (photocells) C13 = Reopen while closing, with immediate closure once the obstruction has been removed, even if the gate is not in motion Open Close
--	--	--

## BUS key selector

Associate a function with the BUS key selector inputs. Different functions can be set according to the key turning direction.

 The function only appears if there is a BUS key selector connected.

<b>Configuration&gt;</b> <b>BUS Devices</b>	<b>BUS 1 key selector</b> <b>BUS 2 key selector</b> <b>BUS 3 key selector</b> <b>BUS 4 key selector</b> <b>BUS 5 key selector</b> <b>BUS 6 key selector</b> <b>BUS 7 key selector</b>	Key to the right Key to the left <hr/> Choose the command to associate with the key movement.  Step-by-step - The first command is to open and the second to close. Sequential - The first command is to open, the second to STOP, the third to close and the fourth to STOP. Open Close Partial opening Stop B1-B2 output BUS 1 module relay - Activate output 2 (relay output) on BUS 1 I/O module BUS 2 module relay - Activate output 2 (relay output) on BUS 2 I/O module
--	---	--

## I/O BUS module - Inputs

Associate a function with the I/O module inputs.

 The function only appears if there is a BUS I/O module connected.

<b>Configuration&gt;</b> <b>BUS Devices&gt;</b> <b>I/O module BUS 1</b> <b>I/O module BUS 2</b>	<b>input I1</b> <b>input I2</b>	Deactivated (Default) Stop = Stop the gate and exclude automatic closing. Use a control device to resume movement.  If it is activated, the input is used as a normally closed contact. r7 = Reopen while closing (sensitive edge with 8K2 resistor) r8 = Reclose while opening (sensitive edge with 8K2 resistor) Partial opening Open Close Step-by-step - The first command is to open and the second to close. Sequential - The first command is to open, the second to STOP, the third to close and the fourth to STOP.
--	------------------------------------	--

### I/O BUS module - Light output

Associate a function with output 1 on the I/O modules.

 The function only appears if there is a BUS I/O module connected.

<b>Configuration&gt;</b>	<b>Light output</b>	Passage-open warning light - It notifies the user of the operator status.
<b>BUS Devices&gt;</b>		 See function [Passage-open warning light].
<b>I/O module BUS 1</b>		Cycle lamp - The lamp stays on during the manoeuvre.
<b>I/O module BUS 2</b>		Courtesy light - The light switches on when a manoeuvre starts and remains on once the manoeuvre has finished, for the time set under the [Courtesy time] function.

### I/O BUS module - Relay output

Associate a function with output 2 on the I/O modules.

 The function only appears if there is a BUS I/O module connected.

<b>Configuration&gt;</b>	<b>Relay output</b>	Bistable
<b>BUS Devices&gt;</b>		Monostable - on from 1 to 180 seconds (Default 1)
<b>I/O module BUS 1</b>		
<b>I/O module BUS 2</b>		

### <Opening colour> BUS flashing beacon

Set the BUS flashing beacon colour during operator opening.

 The function only appears if there is a BUS flashing beacon connected.

<b>Configuration&gt;</b>	<b>Opening colour</b>	White
<b>BUS Devices&gt;</b>		Yellow
<b>BUS flashing beacon</b>		Orange
		Red (Default)
		Purple
		Blue
		Light blue
		Green

### <Closing colour> BUS flashing beacon

Set the BUS flashing beacon colour during operator closing.

 The function only appears if there is a BUS flashing beacon connected.

<b>Configuration&gt;</b>	<b>Closing colour</b>	White
<b>BUS Devices&gt;</b>		Yellow
<b>BUS flashing beacon</b>		Orange
		Red (Default)
		Purple
		Blue
		Light blue
		Green

### BUS flashing beacon <Automatic closing time colour>

Set the BUS flashing beacon colour during the automatic closing time.

 The function only appears if there is a BUS flashing beacon connected.

<b>Configuration&gt;</b>	<b>Auto. cl. colour</b>	Off
<b>BUS Devices&gt;</b>		White
<b>BUS flashing beacon</b>		Yellow
		Orange
		Red
		Purple
		Blue
		Light blue
		Green (Default)

### <Pre-flashing colour> BUS flashing beacon

Set the flash colour for before opening and closing manoeuvres (pre-flash).

 The function only appears if there is a BUS flashing beacon connected.

<b>Configuration&gt;</b> <b>BUS Devices&gt;</b> <b>BUS flashing beacon</b>	<b>Pre-flashing colour</b>	White (Default) Yellow Orange Red Purple Blue Light blue Green
--	----------------------------	---

### <Signal error> BUS flashing beacon

Set the colour of the BUS flashing beacon in the event of an error signal.

 The warning light is activated after sending a command for movement.

 The function only appears if there is a BUS flashing beacon connected.

<b>Configuration&gt;</b> <b>BUS Devices&gt;</b> <b>BUS flashing beacon</b>	<b>Signal error</b>	Deactivated (Default) White Yellow Orange Red Purple Blue Light blue Green
--	---------------------	--

### Signal maintenance

Set the colour of the flash on enabled BUS devices (flashing beacons and selectors) when maintenance is necessary. With the function activated, these devices will signal that maintenance needs to be carried out at the start of each manoeuvre.

 Configure maintenance and set the number of manoeuvres. See function [Configure maintenance].

 The function only appears if there is a BUS flashing beacon or a BUS selector connected.

<b>Configuration&gt;</b> <b>BUS Devices&gt;</b> <b>BUS device lights</b>	<b>Signal maintenance</b>	Deactivated (Default) White Yellow Orange Red Purple Blue Light blue Green
--	---------------------------	--

### Command 2-7

Associate a command to the connected device on 2-7.

<b>Configuration &gt;</b> <b>Command inputs</b>	<b>Command 2-7</b>	Step-by-step (Default) - The first command is to open and the second to close. Sequential - The first command is to open, the second to STOP, the third to close and the fourth to STOP.
--	--------------------	---

### Hold-to-run

With the function active, the operator stops moving (opening or closing) when the control device is released.

 When the function is active, it excludes all other control devices.

<b>Configuration &gt;</b> <b>Functions</b>	<b>Hold-to-run</b>	Deactivated (Default) On
---	--------------------	-----------------------------



## B1-B2 output

Configure the contact.

<b>Configuration &gt;</b>	<b>B1-B2 output</b>	Bistable
<b>Functions</b>		Monostable: on from 1 to 180 seconds (Default 1)

## Removing obstacles

If the function is active, when the operator detects an obstacle via the AST control on the control board or via the sensitive edge, the leaf movement inverts to create the space required to free the obstacle and then stops.

<b>Configuration &gt;</b>	<b>Removing obstacles</b>	Deactivated (Default)
<b>Functions</b>		On

## Automatic closure

Set the time before automatic closure, once the opening travel end point has been reached or once the photocells have caused a partial stop [C3].

 The function does not work if any of the safety devices are triggered when an obstacle is detected, after a complete stop, during a power outage or if there is an error.

<b>Configuration &gt;</b>	<b>Automatic close</b>	Deactivated (Default)
<b>Times</b>		From 1 to 180 seconds

## Automatic closing after partial opening

Set the time before automatic closure after a partial opening command has been performed or after the photocells have caused a partial stop [C3].

 The function does not work if any of the safety devices are triggered when an obstacle is detected, after a complete stop, during a power outage or if there is an error.

<b>Configuration &gt;</b>	<b>Automatic partial close</b>	Off
<b>Times</b>		1 to 180 seconds (Default 10 seconds)

## Passage-open warning light

It notifies the user of the operator status.

<b>Configuration &gt;</b>	<b>Passage-open warning light</b>	Warning light on (Default) - The warning light stays on when the gate is moving or open. Warning light flashing - The warning light flashes every half second when the gate is opening and stays on when the gate is open. The light flashes every second when the gate is closing, and remains off when the gate is closed.
<b>Manage lights</b>		

## Light E1

Choose the operating mode for the lighting device connected to output E1.

<b>Configuration &gt;</b>	<b>Light E1</b>	Flashing beacon (Default)
<b>Manage lights</b>		Cycle lamp - The lamp stays on during the manoeuvre.  The light remains off if an automatic closing time is not set. Courtesy light - The light switches on when a manoeuvre starts and remains on once the manoeuvre has finished, for the time set under the [Courtesy time] function.

## Courtesy time

Define how many seconds the additional light (set up as courtesy light) stays on after an opening or closing manoeuvre.

<b>Configuration &gt;</b>	<b>Courtesy time</b>	60 to 180 seconds (Default 60 seconds)
<b>Manage lights</b>		

### Pre-flashing time

Adjust the time for which the beacon is activated before each manoeuvre.

<b>Configuration &gt;</b> Manage lights	<b>Pre-flashing time</b>	Deactivated (Default) 1 to 10 seconds
--	--------------------------	--

### RSE communication

Configure the function performed by the board inserted in connector RSE1.

 If an RSE card – configured for paired connections – is plugged into the RSE\_1 connector, use the RSE\_2 connector for remote connection (CRP). In this case, a CAME KEY cannot be connected.

<b>Configuration &gt;</b> RSE communication	<b>RSE1</b>	CRP (Default) Paired
--	-------------	-------------------------

### CRP address

Assign a unique identification code (CRP address) to the control board.

 The function is used where there are multiple operators connected to the same communication BUS using the CRP protocol.

<b>Configuration &gt;</b> RSE communication	<b>CRP address</b>	1 to 254 (Default 1)
--	--------------------	----------------------

### RSE speed

Set the remote connection system communication speed on ports RSE1 and RSE2.

<b>Configuration &gt;</b> RSE communication	<b>RSE1 speed</b>	2400 bps
	<b>RSE2 speed</b>	4800 bps
		9600 bps
		14400 bps
		19200 bps
		38400 bps (Default)
		57600 bps
		115200 bps

### Save data

Save user data, timings and configurations to the memory device (memory roll).

 The function is displayed only when a memory roll card is inserted into the control board.

<b>Configuration &gt;</b> External memory	<b>Save data</b>	
--	------------------	--

### Read data

Upload user data, timings and configurations to the memory device (memory roll).

 The function is displayed only when a memory roll card is inserted into the control board.

<b>Configuration &gt;</b> External memory	<b>Read data</b>	
--	------------------	--

### Parameter reset

Restore the factory configurations except for: [users], [timers], [motor type], [CRP address], [RSE speed], [password], [language], [time format] and the settings related to the travel calibration.

<b>Configuration</b>	<b>Parameter reset</b>	Confirm? NO Confirm? YES
----------------------	------------------------	-----------------------------

### Guided procedure (Wizard)

You can use the system configuration wizard.

<b>Configuration</b>	<b>Guided procedure (Wizard)</b>	
----------------------	----------------------------------	--

### New user

Register up to a maximum of 1000 users and assign a function to each one.

 The operation can be carried out by using a transmitter or a BUS selector device (e.g. a keypad or transponder reader). The board that manages the control devices (AF) must be inserted into the connector.

<b>Manage users</b>	<b>New user</b>	<p>Choose the function to be assigned to the user.</p> <p>Step-by-step - The first command is to open and the second to close.                  Sequential - The first command is to open, the second to STOP, the third to close and the fourth to STOP.</p> <p>Open                  Partial opening                  B1-B2 output                  BUS 1 module relay - Activate output 2 (relay output) on BUS 1 I/O module                  BUS 2 module relay - Activate output 2 (relay output) on BUS 2 I/O module</p> <p>Press ENTER to confirm.                  You will be asked to enter your user code. Send the code from the control device (transmitter, keypad or transponder).                  Repeat the procedure to add other users.</p>
---------------------	-----------------	---

### Remove user

Remove one of the registered users.

<b>Manage users</b>	<b>Remove user</b>	<p>Use the arrows to choose the number associated with the user you want to remove.</p> <p> Alternatively, you can select a user by sending a command from the associated device.</p> <p>Press ENTER to confirm                  Confirm? YES                  Confirm? NO</p>
---------------------	--------------------	---

### Remove all

Remove all registered users.

<b>Manage users</b>	<b>Remove all</b>	<p>Confirm? NO                  Confirm? YES</p>
---------------------	-------------------	--

### Radio decoding

Choose the type of radio coding for the transmitters enabled to control the operator.

 If you choose the type of radio coding for the transmitters [Rolling code] or [TW key block], any transmitters saved previously will be deleted.

<b>Manage users</b>	<b>Radio decoding</b>	<p>All decodings                  Rolling code                  TW key block</p> <p>Confirm? NO                  Confirm? YES</p>
---------------------	-----------------------	---

### Rolling self-learning

Save a new rolling code transmitter by activating acquisition from a rolling code transmitter that has already been saved. The saving and acquisition procedures are explained in the transmitter manual.

<b>Manage users</b>	<b>Rolling self-learning</b>	<p>Deactivated (Default)                  On</p>
---------------------	------------------------------	--

## Change mode

Change the function assigned to a specific user.

<b>Manage users</b>	<b>Change mode</b>	Use the arrows to choose the number associated with the user to be changed. Alternatively, you can select a user by sending a command from the associated device. Press ENTER to confirm. Choose the command to associate with the user.  Step-by-step - The first command is to open and the second to close. Sequential - The first command is to open, the second to STOP, the third to close and the fourth to STOP. Open Partial opening B1-B2 output BUS 1 module relay - Activate output 2 (relay output) on BUS 1 I/O module BUS 2 module relay - Activate output 2 (relay output) on BUS 2 I/O module  Press ENTER to confirm. Confirm? NO Confirm? YES
---------------------	--------------------	---

## FW version

Display the firmware version and the GUI installed.

<b>Information</b>	<b>FW version</b>	FW x.x.xx (firmware) GUI x.x (graphics)
--------------------	-------------------	--

## BUS device status

Show the status of all devices that can be connected to the BUS and managed by the firmware in use.

<b>Information</b>	<b>BUS device status</b>	<b>Devices</b> Photocell BUS <n> <n> from 1 to 8 BUS selector <n> <n> from 1 to 7 BUS flashing beacon <n> <n> from 1 to 2 I/O module BUS <n> <n> from 1 to 2	<b>Device statuses available</b> OK Not communicating Safety device active BUS address conflict
--------------------	--------------------------	--	---

## Manoeuvre counter

View the number of total or partial operator manoeuvres (after maintenance).

The number of manoeuvres is the number shown multiplied by 100.

<b>Information</b>	<b>Manoeuvre counter</b>	Total manoeuvres Manoeuvres performed since the operator was installed.  Partial manoeuvres Manoeuvres carried out after the last maintenance.
--------------------	--------------------------	--

## Configure maintenance

Set the number of manoeuvres the operator can perform before a maintenance warning signal is generated.

The warning is displayed as an [Maintenance required] message and signalled by 3 + 3 flashes every hour on the device connected to the 10-5 output.

<b>Information</b>	<b>Maintenance conf.</b>	Deactivated (Default) from 1 x100 to 500 x100
--------------------	--------------------------	--

### Maintenance reset

Reset the number of partial manoeuvres.

Information	Maintenance reset	Confirm? NO Confirm? YES
-------------	-------------------	-----------------------------

### Errors list

View the last 8 errors detected. The error list can be deleted.

Information	Errors list	 Use the arrows to scroll through the list. To cancel the error list, select [Delete errors] Press ENTER to confirm.
-------------	-------------	---

### Show clock

Enable the clock on the display.

Timer management	Show clock	
------------------	------------	--

### Set the clock

Set the date and time.

Timer management	Set the clock	Use the arrows and the Enter button to enter the desired values.
------------------	---------------	--

### Automatic DST

Enable automatic daylight saving time setting.

 Valid in Central Europe only UTC+1.

Timer management	Automatic DST	Deactivated (Default) On Summer changeover: +1 hour on the last Sunday in March (change to daylight saving time). Winter changeover: -1 hour on the last Sunday in October (change to standard time).
------------------	---------------	--

### Time format

Choose the clock display format.

Timer management	Time format	24-hour 12-hour
------------------	-------------	--------------------

### Create new timer

Time one or more types of activation chosen from those available.

 You can set up to 8 timers and 16 special days.

<b>Timer management</b>	<b>Create new timer</b>	Use the arrows to choose the desired command. Open Partial opening B1-B2 output BUS 1 module relay - Activate output 2 (relay output) on BUS 1 I/O module BUS 2 module relay - Activate output 2 (relay output) on BUS 2 I/O module Press ENTER to confirm.  Start time Use the arrows to set the function activation start time. Press ENTER to confirm.  End time Use the arrows to set the function activation end time. Press ENTER to confirm.  Days of the week Use the arrows to set the function activation days. Select days All week Press ENTER to confirm.
-------------------------	-------------------------	--

### Remove timer

Removes one of the saved timings.

<b>Timer management</b>	<b>Remove timer</b>	Use the arrows to choose the timing to be removed. O = [Opening] P = [Partial opening] B = [Output B1-B2] R = [BUS module relay] Press ENTER to confirm.
-------------------------	---------------------	---

### Language

Set the display language.

<b>Language</b>	Italiano (IT) English (EN) (Default) Français (FR) Deutsch (DE) Español (ES) Português (PT) Русский (RU) Polski (PL) Românesc (RO) Magyar (HU) Hrvatski (HR) Український (UA) Nederlands (NL)
-----------------	---

### Enable password

Set a 4-digit password. The password will be requested to anyone who wants to access the main menu.

 This option only shows if a password has NOT been enabled.

<b>Password</b>	<b>Enable password</b>	Use the arrows and the Enter button to dial the desired code. Enter the password again using the arrows and the Enter button to confirm.
-----------------	------------------------	---

### Remove password

Remove the password that protects access to the main menu.

This option only shows if a password has been enabled.

Password	Remove password	Confirm? NO Confirm? YES
----------	-----------------	-----------------------------

### Change password

Change the password protecting access to the main menu.

This option only shows if a password has been enabled.

Password	Change password	Use the arrows and the Enter button to dial the desired code. Enter the password again using the arrows and the Enter button to confirm.
----------	-----------------	---

### Forgotten password

If you lose the password, you will need to reset the board to its factory settings. See [Factory reset].

### Factory reset

To restore the electronic board data to factory settings:

Disconnect the control board from the power supply.

Press and hold the < and > buttons, then reconnect the control board to the power supply.

Continue to press and hold the < > buttons until [Factory reset] is displayed.

Select [Confirm YES].

Press ENTER to confirm.

When you reset the control board, all saved users, set times, manoeuvre configurations and calibration operations are deleted.

**When using a CAME KEY device, always update the board firmware to the latest version.**

### Import/export data

Save user data and system configuration data on a MEMORY ROLL card.

The stored data can be reused for another control board of the same type to carry across the same configuration.

Before inserting and removing the MEMORY ROLL card, DISCONNECT THE MAINS POWER SUPPLY TO THE LINE.

**1** Insert the MEMORY ROLL card into the corresponding connector on the control board.

**2** Press the "Enter" button to access programming.

**3** Use the arrows to choose the desired function.

Configuration > External memory > **Save data**

Save user data, timings and configurations to the memory device (memory roll).

Configuration > External memory > **Read data**

Upload user data, timings and configurations to the memory device (memory roll).

Once the data have been saved and loaded, the MEMORY ROLL can be removed.

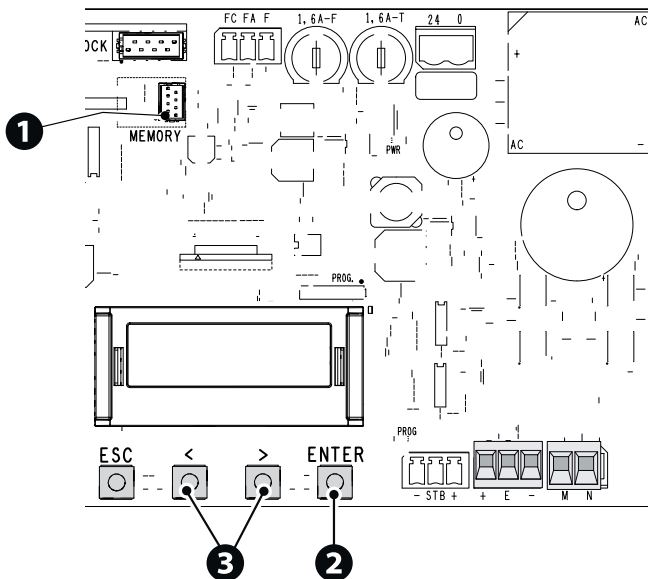

## FINAL OPERATIONS

 Before closing up the casing, check that the cable inlets are sealed to stop insects getting in and to prevent damp.

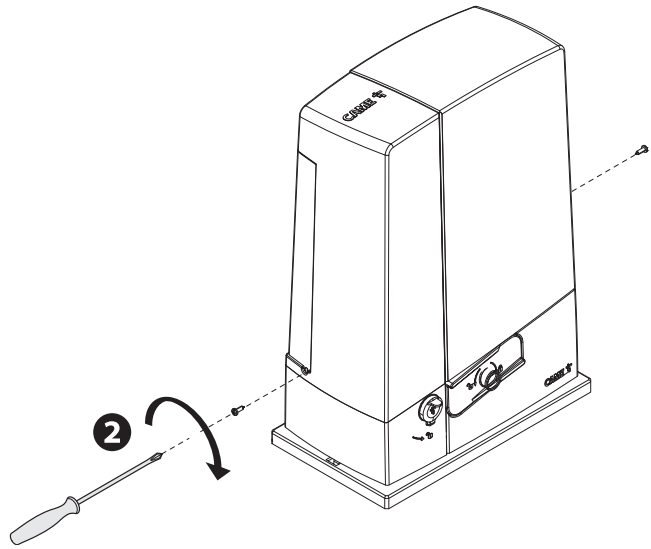
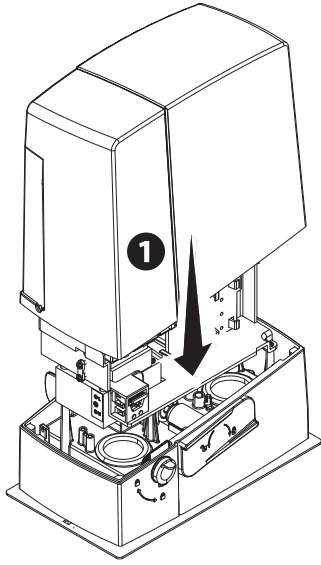



## PAIRED OPERATION

Two connected operators are controlled with one command.

### Electrical connections

Connect the two electronic boards with a UTP CAT 5 cable.

Insert an RSE card into both control boards.

Connect up the electrics for the devices and accessories.

 The devices and accessories must be connected to the control board which will be set as the MASTER.

 For information on connecting the electrics for the devices and accessories, please see the “ELECTRICAL CONNECTIONS” section.

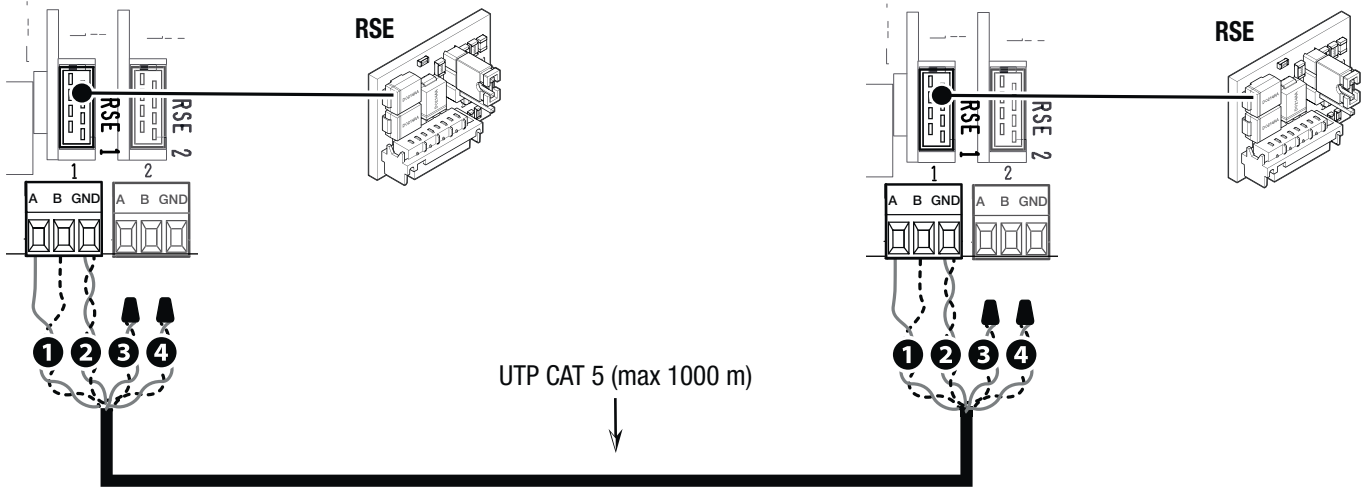

### Programming

 All programming operations described below must be performed only on the control board set as the MASTER.

Select the [Paired] system type when following the guided procedure, or configure the RSE\_1 port to [Paired] mode.

 After programming the MASTER operator in [Paired], the second operator automatically becomes SLAVE.

### Saving users

 All save user operations must be performed only on the control board set as the MASTER.







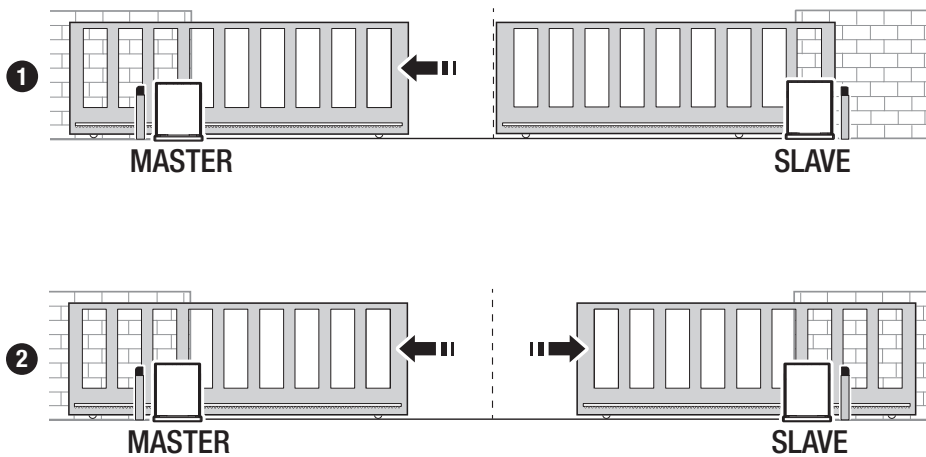







### Operating modes

**1** PARTIAL OPENING command

**2** STEP-BY-STEP command



## DISPLAY WARNINGS KEY

	The [Impact test] function is on.
	The operator detected an obstacle during closing.
	The operator detected an obstacle during opening.
	The operator detected two obstacles during closing.  The number on the display varies according to the number of obstructions detected.  When the maximum number of detected obstructions has been reached, the operator stops and an error message shows on the display.
	The operator detected two obstacles during opening.  The number on the display varies according to the number of obstructions detected.  When the maximum number of detected obstructions has been reached, the operator stops and an error message shows on the display.
	There is at least one programmed timer.
	A programmed timer is running.  With the timer programmed for opening or partial opening, any given radio command will always allow opening. The wired commands continue to operate normally.
<b>C&lt;n&gt;</b>	Wired safety device active  The <n> value is associated with the selected parameter for the functions [CX input] [CY input] [CK input] [CZ input].
<b>r7</b>	R7 safety device (sensitive edge) active
<b>r8</b>	R8 safety device (sensitive edge) active
<b>2r7</b>	R7 safety device (pair of sensitive edges) active
<b>2r8</b>	R8 safety device (pair of sensitive edges) active
<b>c&lt;n&gt;</b>	BUS photocell safety device active  The <n> value is associated with the selected parameter for the [BUS photocell] functions.
<b>c23</b>	Open command active for BUS photocells
<b>c24</b>	Close command active for BUS photocells
<b>C0</b>	Total stop active
<b>P&lt;n&gt;</b>	RIO safety device active  The <n> value is associated with the selected parameter for the functions [RIO ED T1 - RIO ED T2] and [RIO PH T1 - RIO PH T2]
<b>BUS address conflict</b>	ID conflict detected on BUS devices.
<b>Check BUS device</b>	No BUS device with a safety function configured.
<b>RIO not configured</b>	The RIO Conn board is not configured or has no safety configuration.
<b>Calibration needed</b>	Travel calibration required.
<b>Guided procedure (Wizard)</b>	Follow the on-screen wizard.

Maintenance required	Maintenance required (excl. encoder and manoeuvres exceeded for maintenance).
OP	Passage fully open
CL	Passage fully closed

## ERROR MESSAGES

E2	Calibration error
E3	Encoder signal not detected error
E4	Service test failure error
E6	Motor failure error
E7	Operating time error
E8	Open release-hatch error
E9	Obstacle detected during closing
E10	Obstacle detected during opening
E11	The maximum number of obstacles detected consecutively has been exceeded
E12	No line voltage
E14	Serial communication error
E15	Incompatible transmitter error
E16	Open SLAVE-motor hatch error
E17	Wireless system communication error
E18	Wireless system not configured error
E22	FW update error
E24	BUS device communication error <b>During a manoeuvre:</b> communication error or malfunction of a BUS safety device
E25	Address settings error on BUS devices
E27	Communication error with motor

## MCBF

Models	BXV04AGE	BXV06AGE	BXV10AGE	BXV04AGM	BXV06AGM	BXV10AGM
Length - Weight	14 m - 400 kg	18 m - 600 kg	20 m - 1000 kg	14 m - 400 kg	18 m - 600 kg	20 m - 1000 kg
MCBF	150000	150000	150000	150000	150000	150000
Installation in windy area (%)	-15 %	-15 %	-15 %	-15 %	-15 %	-15 %

 The percentages indicate how much the number of cycles should be reduced in relation to the type and number of accessories installed.

 Before carrying out any cleaning or maintenance, or replacing any parts, disconnect the device from the power supply.

 This document informs the installer of the checks that must be carried out during maintenance.

 If the system is not used for long periods of time, e.g. for installations at sites with seasonal closures, disconnect the power supply. When the power supply is reconnected, check the system is working correctly.

 For information on correct installation and adjustments, please see the product installation manual.

 For information on choosing products and accessories, please see our product catalogue.

 Every 10,000 cycles and, in any case, every 6 months of operation, you must perform the maintenance work indicated below.

Perform a general and complete check of the tightness of the nuts and bolts.

Grease all of the moving mechanical parts.

Check the warning and safety devices are working properly.

Check for any wear on the moving mechanical parts and check that they are working properly.

Check the release mechanism is working efficiently by performing a manoeuvre with the leaf free. The gate leaf must not be obstructed.

Check the cables are intact and connected correctly.

Check and clean the track guide and rack.



**CAME** 

**CAME.COM**

**CAME S.P.A.**

Via Martiri della Libertà, 15

31030 Dosson di Casier

Treviso – Italy

Tel. (+39) 0422 4940

Fax (+39) 0422 4941