

## Sliding-gate operators

FA02214-EN



**BX704AGS**  
**BX704ALS**

**BX708AGS**

**BX708RGS**  
**BX708ALS**

INSTALLATION MANUAL



1

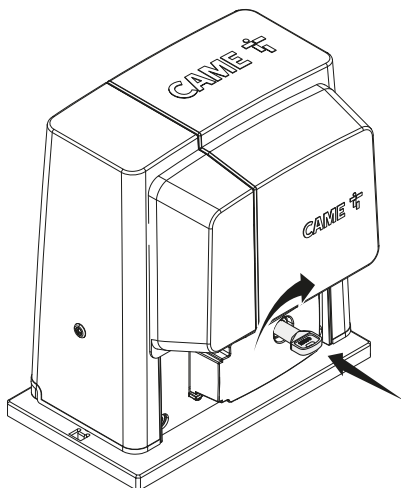

2

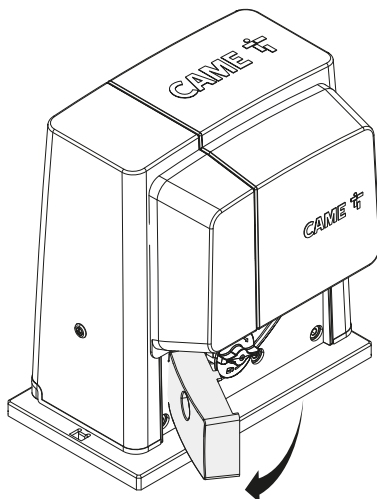

3

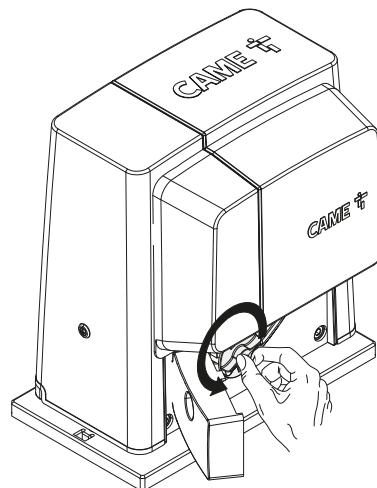

1

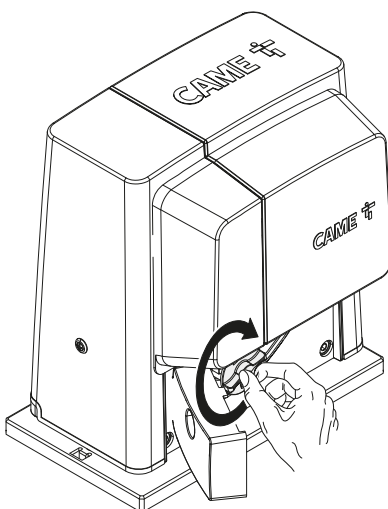

2

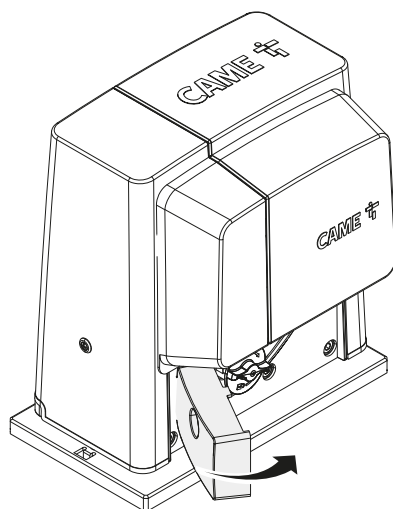

3

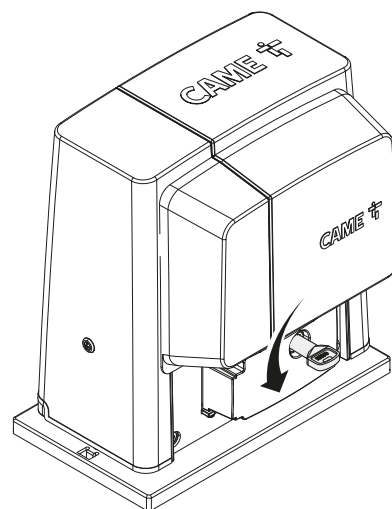

**⚠ Important safety instructions.**

**⚠ Please follow all of these instructions. Improper installation may cause serious bodily harm.**

**⚠ Before continuing, please also read the general precautions for users.**

Only use this product for its intended purpose. Any other use is hazardous.

- The manufacturer cannot be held liable for any damage caused by improper, unreasonable or erroneous use.
- This product is defined by the Machinery Directive (2006/42/EC) as partly completed machinery.
- Partly completed machinery means an assembly which is almost machinery but which cannot in itself perform a specific application.
- Partly completed machinery is only intended to be incorporated into or assembled with other machinery or other partly completed machinery or equipment thereby forming machinery to which the Machinery Directive (2006/42/EC) applies.
- The final installation must comply with the Machinery Directive (2006/42/EC) and the European reference standards in force.
- The manufacturer declines any liability for using non-original products, which would also void the warranty.
- All operations indicated in this manual must be carried out exclusively by skilled and qualified personnel and in full compliance with the regulations in force.
- The device must be installed, wired, connected and tested according to good professional practice, in compliance with the standards and laws in force.
- Make sure the mains power supply is disconnected during all installation procedures.
- Check that the temperature ranges given are suitable for the installation site.
- Do not install on slopes i.e. any surfaces that are not perfectly level.
- Do not install the operator on surfaces that could yield and bend. If necessary, add suitable reinforcements to the anchoring points.
- Make sure that no direct jets of water can wet the product at the installation site (sprinklers, water cleaners, etc.).
- Make sure you have set up a suitable dual-pole cut-off device along the power supply that is compliant with the installation rules. It should completely cut off the power supply according to category III surcharge conditions.
- Demarcate the entire site properly to prevent unauthorised personnel from entering, especially minors.
- In case of manual handling, have one person for every 20 kg that needs hoisting; for non-manual handling, use proper hoisting equipment in safe conditions.
- Use suitable protection to prevent any mechanical hazards due to persons loitering within the operating range of the operator.
- The electrical cables must pass through special pipes, ducts and cable glands in order to guarantee adequate protection against mechanical damage.
- The electrical cables must not touch any parts that may overheat during use (such as the motor and transformer).
- Before installation, check that the guided part is in good mechanical condition, and that it opens and closes correctly.
- The product cannot be used to automate any guided part that includes a pedestrian gate, unless it can only be enabled when the pedestrian gate is secured.
- Make sure that nobody can become trapped between the guided and fixed parts, when the guided part is set in motion.
- Use additional protection to prevent your fingers from being crushed between the pinion and rack.
- All fixed controls must be clearly visible after installation, in a position that allows the guided part to be directly visible, but far away from moving parts. In the case of a hold-to-run control, this must be installed at a minimum height of 1.5 m from the ground and must not be accessible to the public.
- If not already present, apply a permanent tag that describes how to use the manual release mechanism close to it.
- Make sure that the operator has been properly adjusted and that the safety and protection devices and the manual release are working properly.
- Before handing over to the final user, check that the system complies with the harmonised standards and the essential requirements of the Machinery Directive (2006/42/EC).
- Any residual risks must be indicated clearly with proper signage affixed in visible areas, and explained to end users.
- Put the machine's ID plate in a visible place when the installation is complete.
- If the power-supply cable is damaged, it must be immediately replaced by the manufacturer or by an authorised technical assistance centre, or in any case, by qualified staff, to prevent any risk.
- Keep this manual inside the technical folder along with the manuals of all the other devices used for your automation system.
- Make sure to hand over to the end user all the operating manuals of the products that make up the final machinery.

## Main points of danger for people

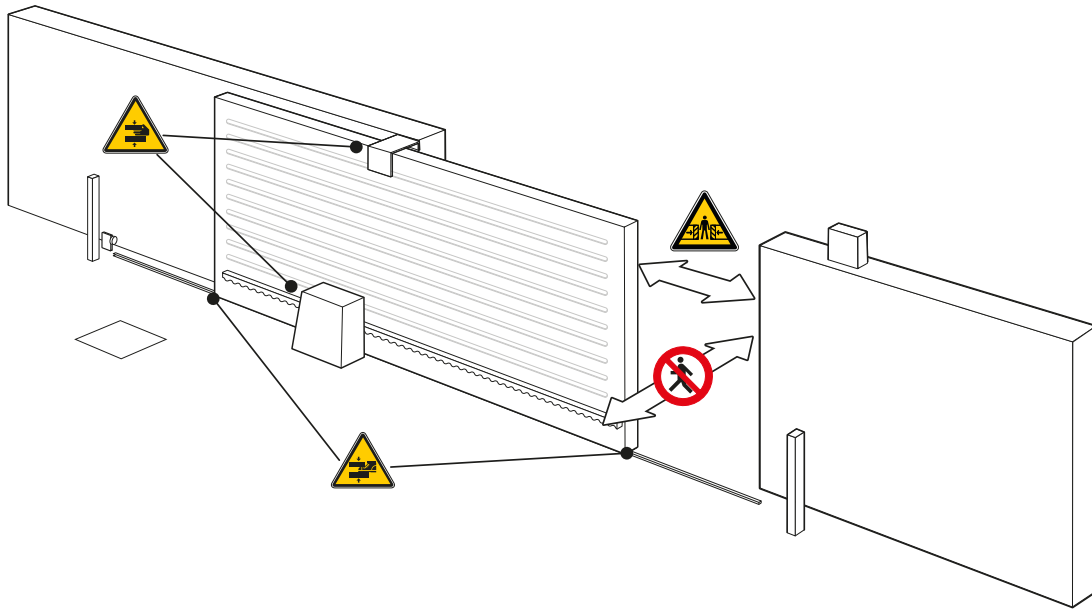

 No transiting while the barrier is moving.

 Risk of entrapment.

 Risk of trapping hands.

 Risk of trapping feet.

## DISMANTLING AND DISPOSAL

 CAME S.p.A. employs an Environmental Management System at its premises. This system is certified and compliant with the UNI EN ISO 14001 standard to ensure that the environment is respected and safeguarded. Please continue safeguarding the environment. At CAME we consider it one of the fundamentals of our operating and market strategies. Simply follow these brief disposal guidelines:

### DISPOSING OF THE PACKAGING

The packaging materials (cardboard, plastic, etc.) can be disposed of easily as solid urban waste, separated for recycling.

Before dismantling and disposing of the product, please always check the local laws in force.

### DISPOSE OF THE PRODUCT RESPONSIBLY

#### DISPOSING OF THE PRODUCT

Our products are made of various materials. Most of these materials (aluminium, plastic, iron and electrical cables) are classified as solid urban waste. They can be separated for recycling and disposed of at authorised waste treatment plants.

Other components (electronic boards, transmitter batteries, etc.) may contain pollutants.





These must be removed and disposed of by an authorised waste disposal and recycling firm.

It is always advisable to check the specific laws that apply in your area.

### DISPOSE OF THE PRODUCT RESPONSIBLY

### Key

---

-  This symbol shows which parts to read carefully.
-  This symbol shows which parts describe safety issues.
-  This symbol shows what to tell users.
-  The measurements, unless otherwise stated, are in millimetres.

### Description

---

#### 801MS-0020

BX704AGS - Operator with 230 V motor, featuring a control board with programming display, on-board radio decoding, movement and obstruction detecting device with mechanical limit switch for sliding gates weighing up to 400 kg that are up to 14 m long. RAL7024 grey cover.

#### 801MS-0030

BX708AGS - Operator with 230 V motor, featuring a control board with programming display, on-board radio decoding, movement and obstruction detecting device with mechanical limit switch for sliding gates weighing up to 800 kg that are up to 14 m long. RAL7024 grey cover.

#### 801MS-0021

BX704ALS - Operator complete with control board with programming display, built-in radio decoder, movement and obstruction-detection device and mechanical limit switches for sliding gates weighing up to 400 kg that are up to 14 m in length.

#### 801MS-0031

BX708ALS - Operator complete with control board with programming display, built-in radio decoder, movement and obstruction-detection device and mechanical limit switches for sliding gates weighing up to 800 kg that are up to 14 m in length.



#### 801MS-0060

BX708RGS - Operator complete with control board with programming display, built-in radio decoder, movement and obstruction-detection device and mechanical limit switches for sliding gates weighing up to 800 kg that are up to 14 m in length.

### Intended use

---

Sliding gate solution for residential buildings

-  Any installation and/or use other than that specified in this manual is forbidden.
-  With the Green Power module connected to the operator, the end installations fall within the scope of Regulation (EU) 2023/826; "Household and Office" spaces.

## Description of parts

### Operator

- ❶ Cover
- ❷ Front cover
- ❸ Gearmotor
- ❹ Capacitor
- ❺ Mechanical limit switch
- ❻ Anchoring plate
- ❼ Control board holder
- ❽ Control board
- ❾ Limit-switch tabs
- ❿ Transformer
- ⓫ Release hatch
- ⓬ Fixtures and fittings
- ⓭ Module housing

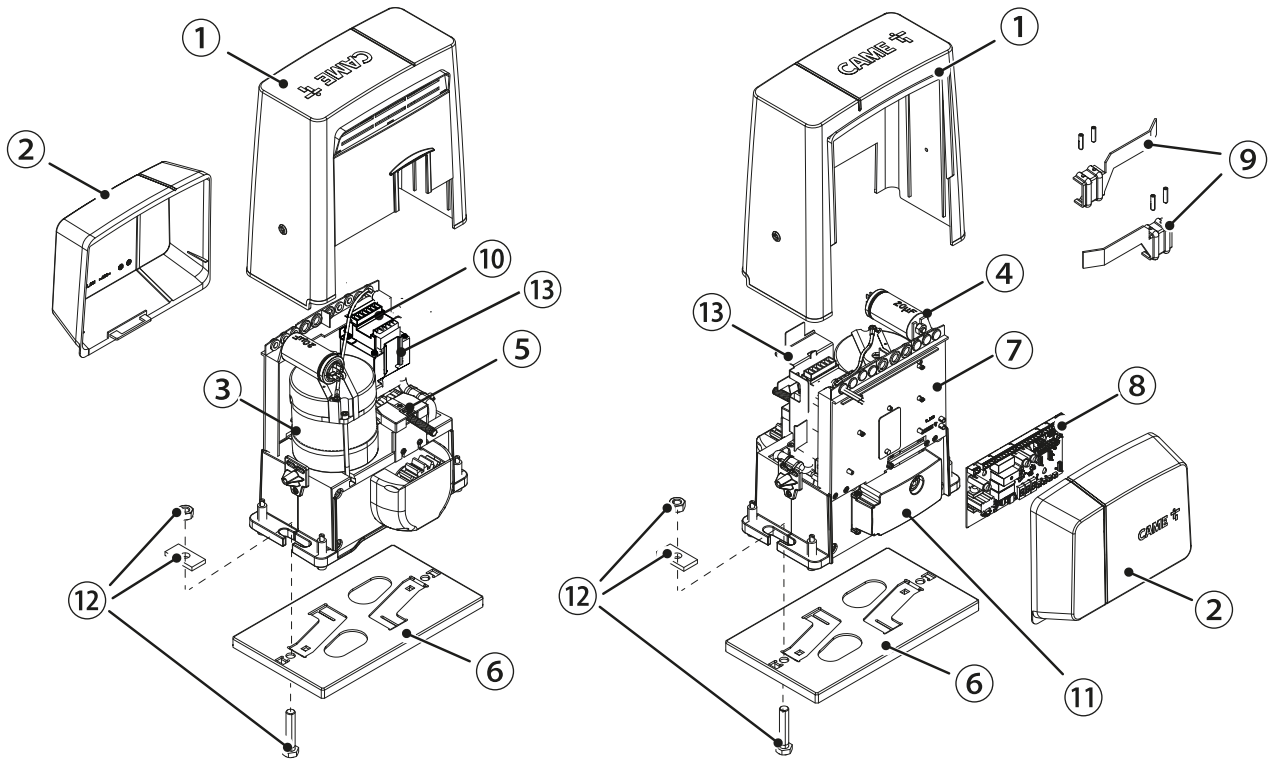

## Control board

The functions on the input and output contacts, the time settings and user management are set and viewed on the display.

All connections are protected by quick fuses.

For the system to work properly, before fitting any plug-in card, DISCONNECT THE MAIN POWER SUPPLY and remove any batteries.

Before working on the control panel, disconnect the mains power supply and remove the batteries, if any.

- |   |   |
|---|---|
| <ul style="list-style-type: none"> <li>❶ Power supply terminal board</li> <li>❷ Terminal board for connecting the gearmotor</li> <li>❸ Terminal board for connecting the transformer</li> <li>❹ Control board fuse</li> <li>❺ Terminal board for connecting control and safety devices</li> <li>❻ Accessories fuse</li> <li>❼ Terminal board for connecting the RGP1 module</li> <li>❽ Terminal board for connecting the encoder</li> <li>❾ Terminal board for connecting the keypad selector</li> <li>❿ Terminal board for connecting the limit switches</li> <li>⓫ Terminal board for connecting the antenna</li> </ul> | <ul style="list-style-type: none"> <li>❿ Connector for plug-in radio frequency card (AF)</li> <li>⓬ Terminal board for connecting the transponder selector switch</li> <li>⓭ Terminal board for connecting the paired function or the CRP</li> <li>⓮ Connector for the R700 or R800 decoding card</li> <li>⓯ Connector for the RIOCN8WS module</li> <li>⓰ RSE card connector</li> <li>⓱ Programming buttons</li> <li>⓲ Memory Roll card connector</li> <li>⓳ Display</li> <li>⓴ Power LED</li> <li>⓵ Line fuse</li> </ul> |
|---|---|

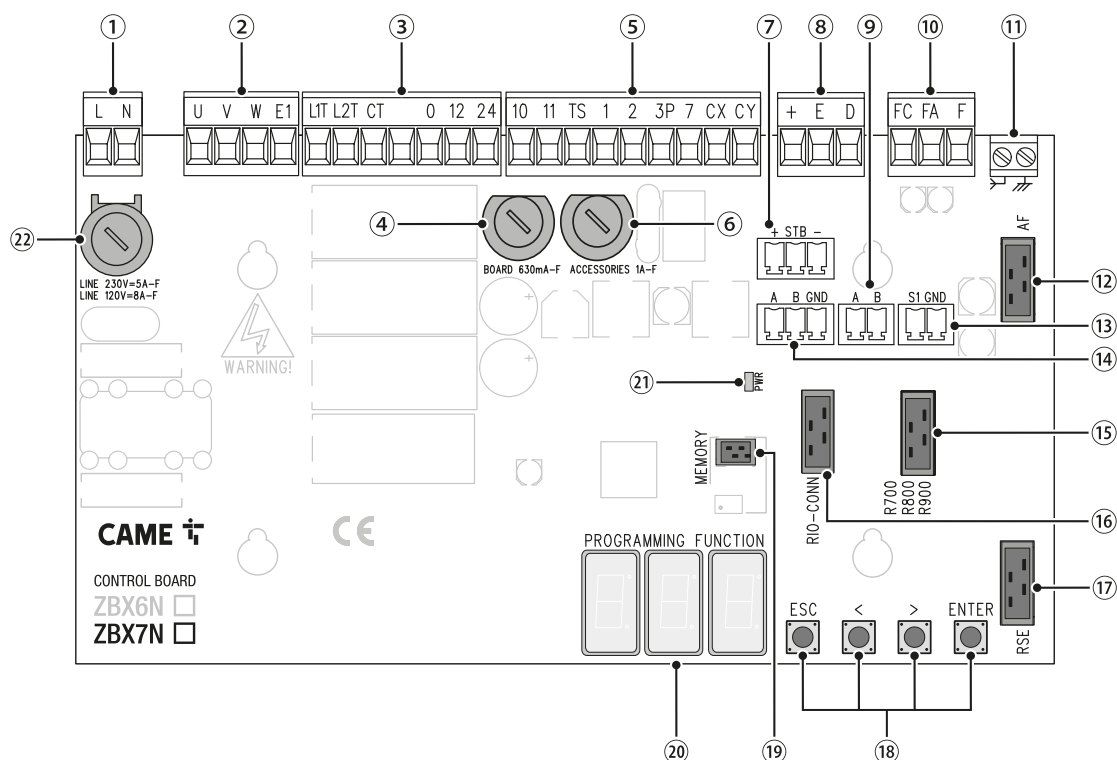

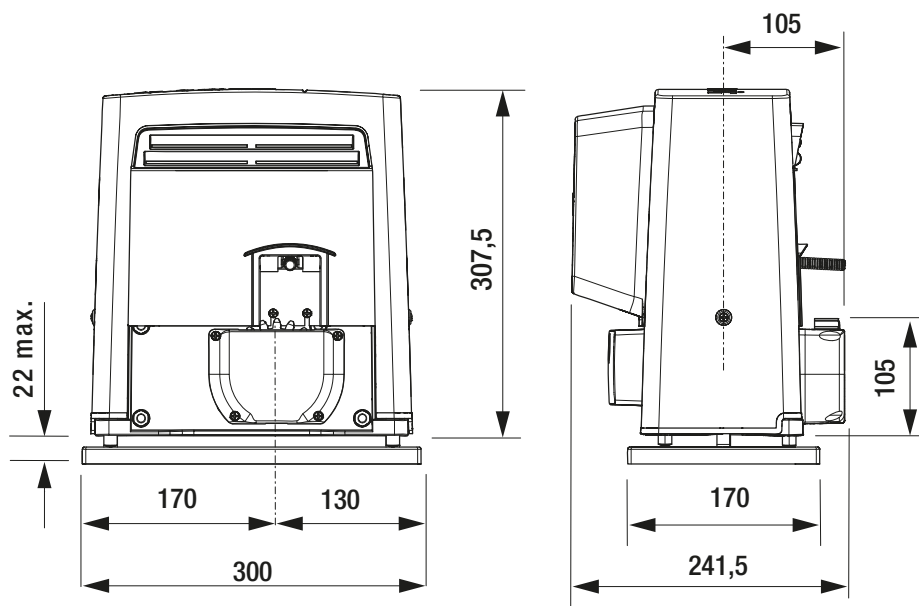

Usage limitations

MODELS	BX704AGS	BX708AGS	BX708RGS
Maximum gate-leaf length (m)	14	14	14
Maximum gate-leaf weight (kg)	400	800	800

Technical data

MODELS	BX704AGS	BX708AGS	BX708RGS
Power supply (V - 50/60 Hz)	230 AC	230 AC	120 AC
Motor power supply (V)	230 AC	230 AC	120 AC
Power (W)	320	520	530
Capacitor (µF)	12	20	80
Current draw (A)	1,5	2,5	4,5
Colour	RAL 7024	RAL 7024	RAL 7024
Thrust (N)	600	800	800
Maximum operating speed (m/min)	10,5	10,5	10,5
Cycles/hour	17	17	17
Consecutive cycles	6	6	6
Sound pressure level (dB A)	≤70	≤70	≤70
Control board	ZBX7N	ZBX7N	ZBX7N
Pinion module	4	4	4
Reduction ratio	33	33	33
Limit-switch type	MECHANICAL	MECHANICAL	MECHANICAL
Protection rating (IP)	44	44	44
Insulation class	I	I	I
Weight (kg)	15	15	15

Fuse table

MODELS	BX704AGS	BX708AGS	BX708RGS
Line fuse	5 A-F	5 A-F	8 A-F
Control-board fuse	630 mA-F	630 mA-F	630 mA-F
Accessories fuse	1 A-F	1 A-F	1 A-F

## Operating cycles

The operating cycle calculation considers a gate that is of standard length (the sliding part), professionally installed, free of any mechanical issues and/or accidental friction points, and measured at an ambient temperature of 20°C, as stated in EN standard 60335-2-103.

MODELS	BX704AGS	BX708AGS	BX704ALS	BX708ALS	BX708RGS
Cycles/hour (no.)	17	17	17	17	17
Consecutive cycles (no.)	6	6	6	6	6
Standard reference length of the sliding part (m)	-	-	4	4	-

 For gates where the sliding part is of a different length to the standard measurement, please see the graphs.

### Cycles/hour graph

- A** Number of cycles
- B** Gate length

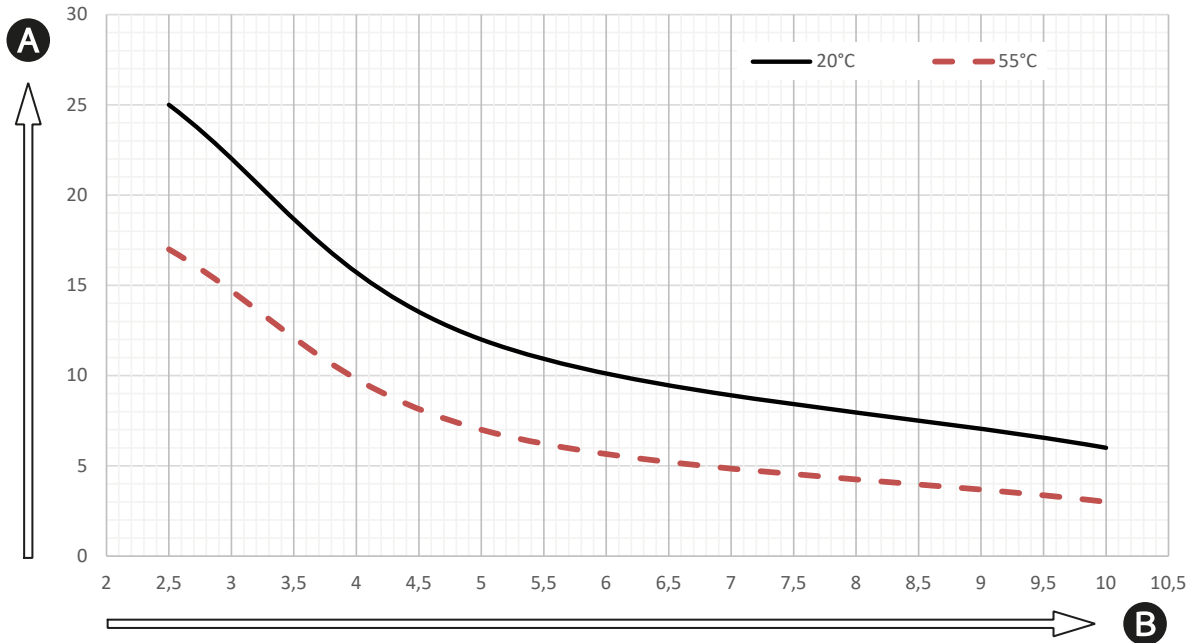

### Consecutive cycles graph

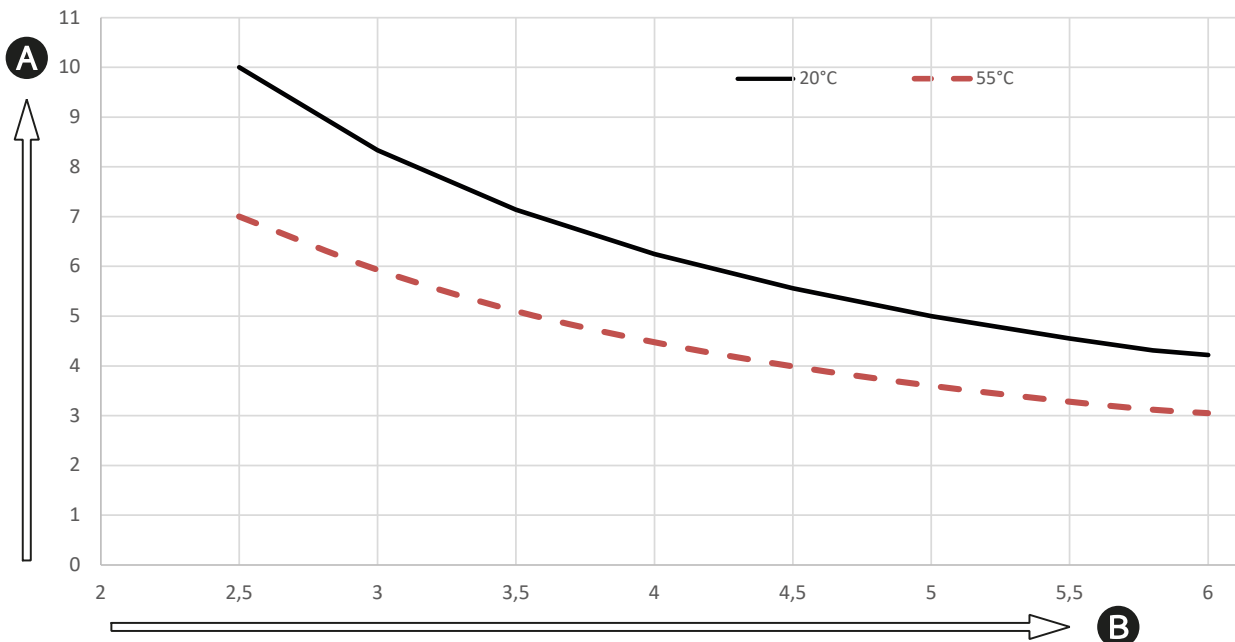



## Cable types and minimum thicknesses

Cable length (m)	up to 20	from 20 to 30
Power supply 230 V AC	3G x 1.5 mm <sup>2</sup>	3G x 2.5 mm <sup>2</sup>
Flashing beacon 230 V AC	2 x 1.5 mm <sup>2</sup>	2 x 1.5 mm <sup>2</sup>
TX Photocells	2 x 0.5 mm <sup>2</sup>	2 x 0.5 mm <sup>2</sup>
RX photocells	4 x 0.5 mm <sup>2</sup>	4 x 0.5 mm <sup>2</sup>
Command and control devices	* no. x 0.5 mm <sup>2</sup>	* no. x 0.5 mm <sup>2</sup>

\* no. = see product assembly instructions - Warning: the cable cross-section is indicative and varies according to the motor power and cable length.

 When operating at 230 V and outdoors, use H05RN-F cables compliant with 60245 IEC 57 (IEC); when operating indoors, use H05VV-F cables compliant with 60227 IEC 53 (IEC). For power supplies up to 48 V, you can use FROR 20-22 II cables compliant with EN 50267-2-1 (CEI).

 To connect the antenna, use RG58 cable (up to 5 m).

 For paired connection and CRP, use UTP CAT5 cable (up to 1,000 m).

 If the cable lengths differ from those specified in the table, define the cable cross-sections according to the actual power draw of the connected devices and in line with regulation CEI EN 60204-1.

 For multiple, sequential loads along the same line, recalculate the values in the table according to the actual power draw and distances. For information on connecting products not covered in this manual, please see the documentation accompanying the products themselves.

## INSTALLATION

 The following illustrations are examples only. The space available for fitting the operator and accessories varies depending on the area where it is installed. It is up to the installer to find the most suitable solution.

 The drawings show an operator fitted on the left.

### Preliminary operations

Dig a hole for the foundation frame.

Set up the corrugated tubes needed for the wiring coming out of the junction pit.

 Use  $\varnothing 40$  mm corrugated tubes to connect the gearmotor to the accessories.

 The number of tubes depends on the type of system and the accessories that are going to be fitted.

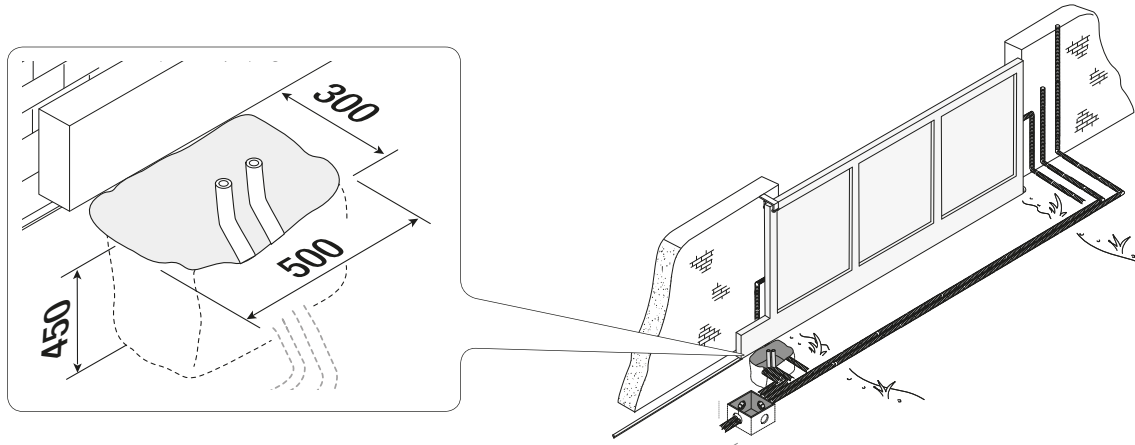

### Laying the anchoring plate

Set up a foundation frame that is larger than the anchoring plate.

Insert the foundation frame into the dug hole.

 The foundation frame must protrude by 50 mm, above ground level.

Fit an iron cage in the foundation frame to reinforce the concrete.

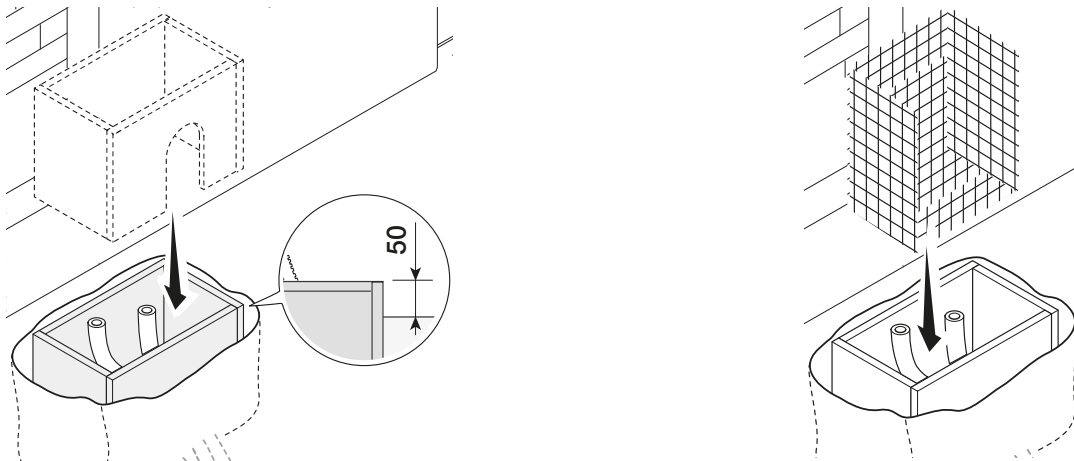

Insert the screws supplied in the anchoring plate.  
 Lock the screws in place with the nuts supplied.  
 Remove the pre-shaped clamps using a screwdriver.  
 Fit the anchoring plate in the iron cage.

 The tubes must pass through the existing holes.

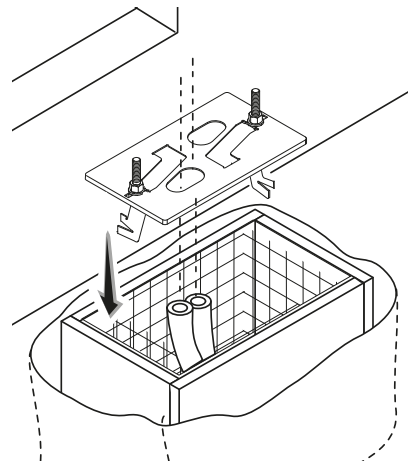
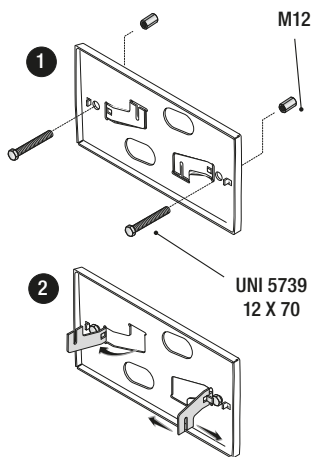

Position the anchoring plate, taking note of the measurements shown in the drawing.

 If the gate does not have a rack, proceed with the installation. See the section FASTENING THE RACK.

 See the section "FASTENING THE RACK".

Cast cement into the foundation frame.

 The plate must be perfectly level and the screw threads completely above surface.

Wait at least 24 hours for the cement to dry.

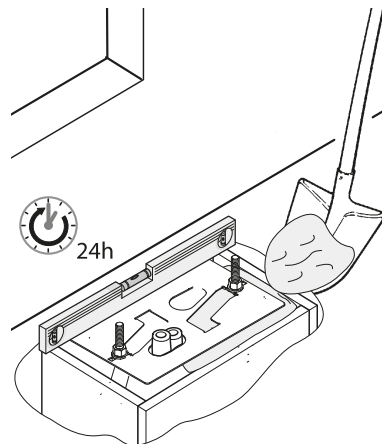
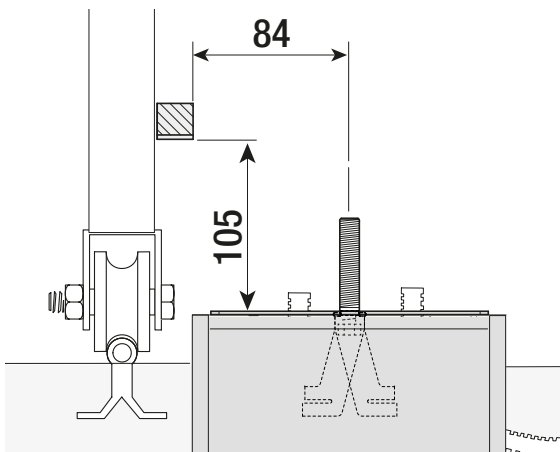

Remove the foundation frame.

Fill the hole with soil around the concrete block.

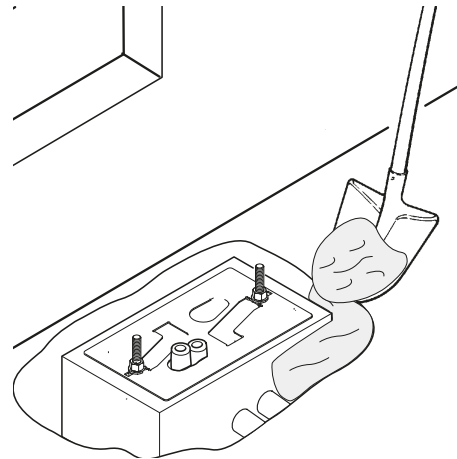
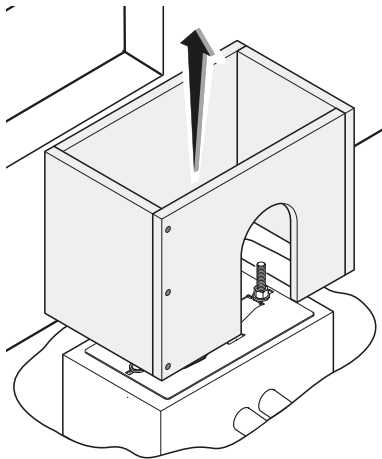

Remove the nuts from the screws.  
Insert the electrical cables into the tubes until they protrude by about 600 mm.

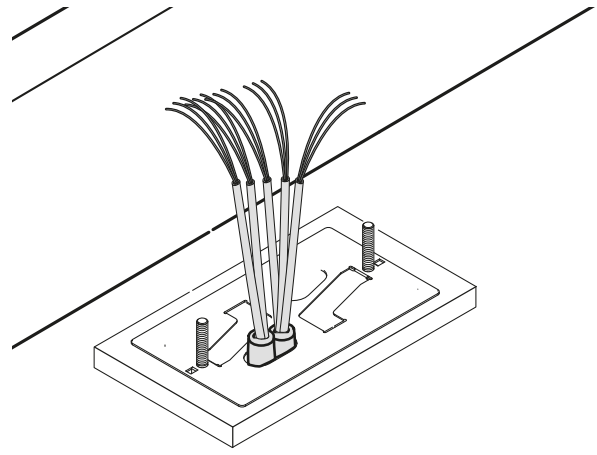
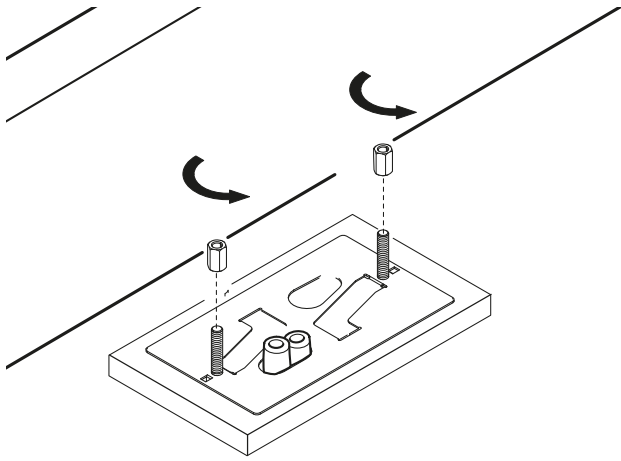

## Setting up the operator

Remove the front cover. **1 2 3**

Remove the operator cover. **4 5**

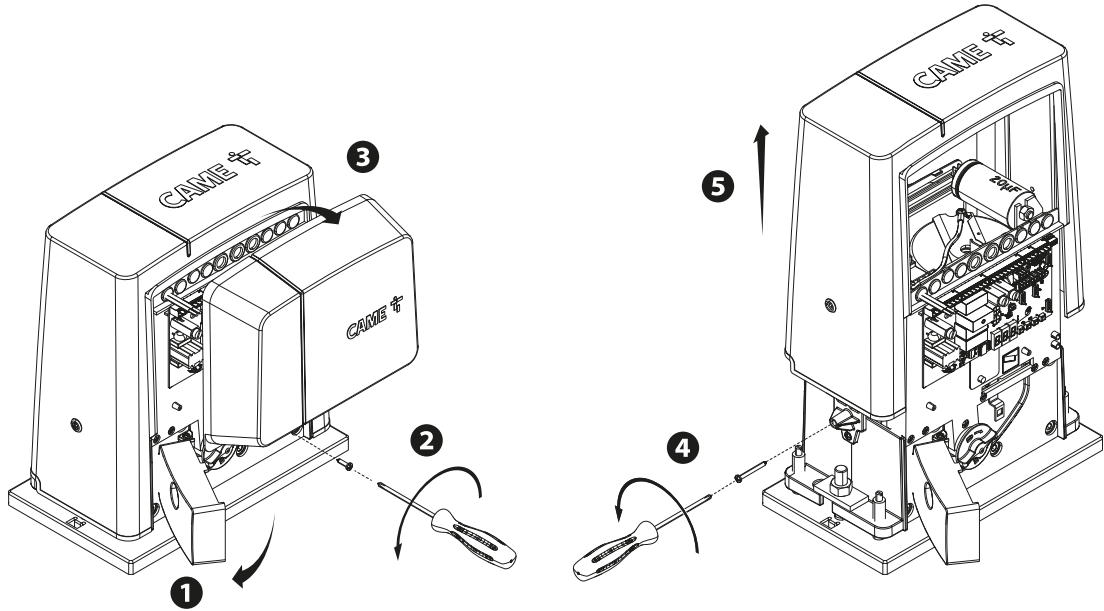

Place the operator on top of the anchoring plate.

 The electrical cables must pass under the operator foundation frame

Lift the operator by 5-10 mm from the plate by adjusting the threaded feet, to allow for any adjustments that may need to be made between the rack and pinion.

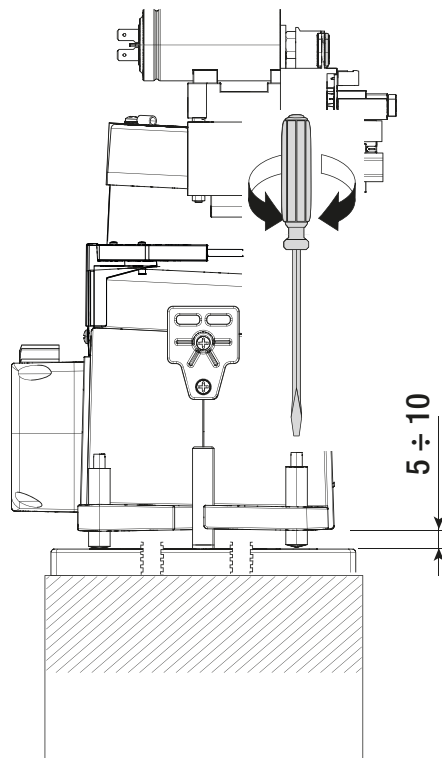
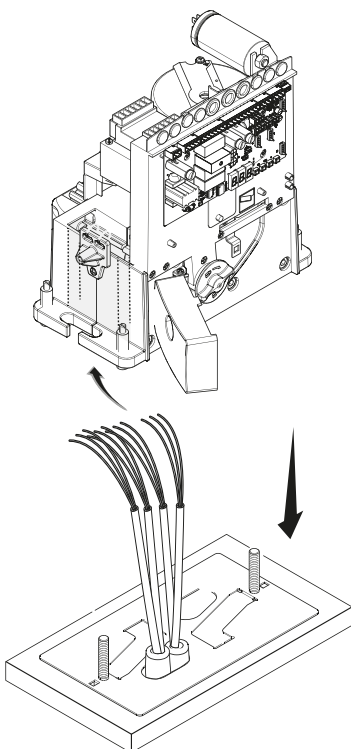

## Fastening the rack

- 1 Release the operator.
- 2 Rest the rack on the pinion.
- 3 Weld or fasten the rack to the gate along its entire length.

 To assemble the rack modules, use an extra piece and rest it under the joint, then fasten it in place using two clamps.

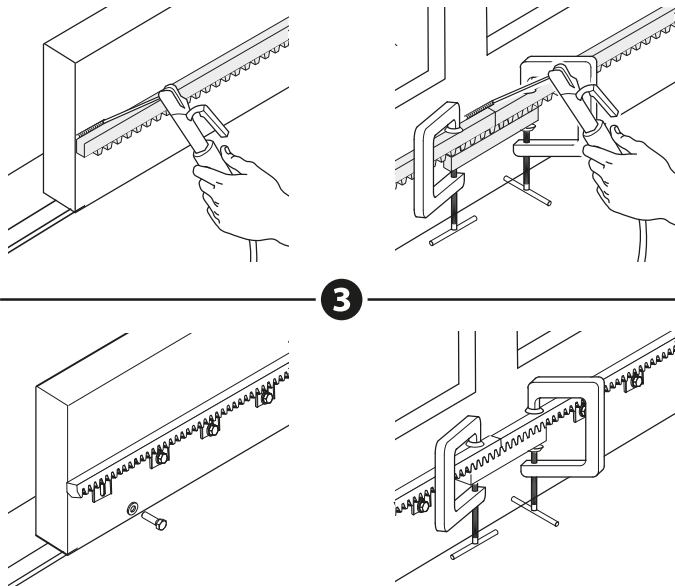
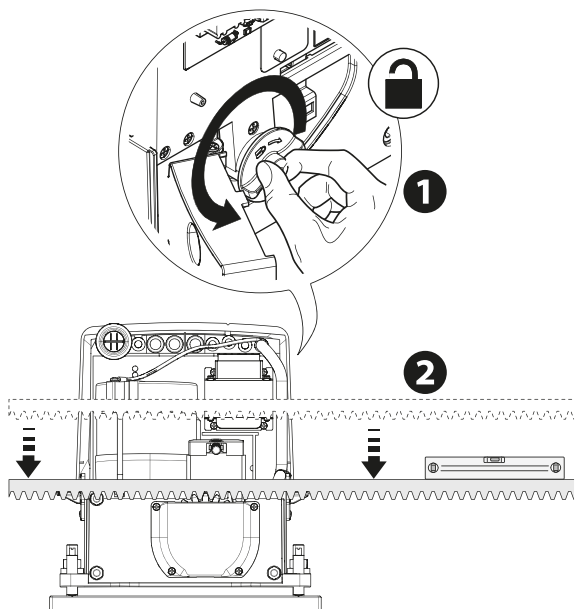

## Adjusting the pinion-rack coupling

Open and close the gate manually.

Adjust the pinion-rack coupling distance using the threaded feet (vertical adjustment) and the holes (horizontal adjustment).

 The weight of the gate must not bear down upon the operator.

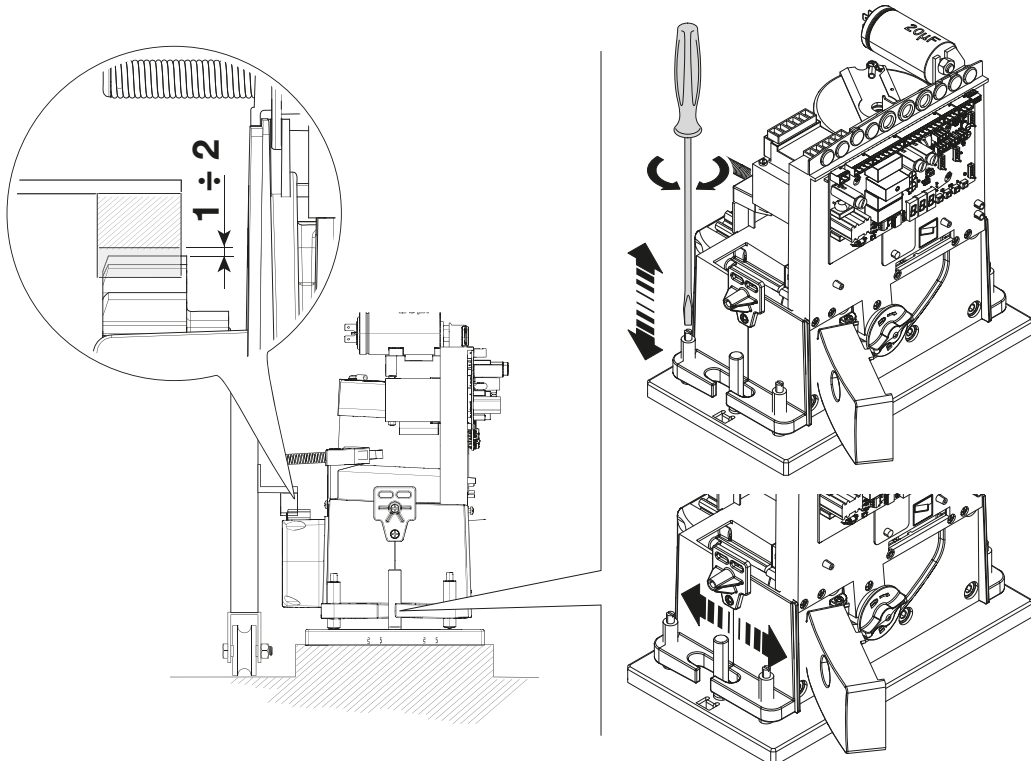

## Fastening the operator in place

 Only fasten the operator after adjusting the pinion-rack coupling.

Fasten the operator to the anchoring plate using stoppers and nuts.

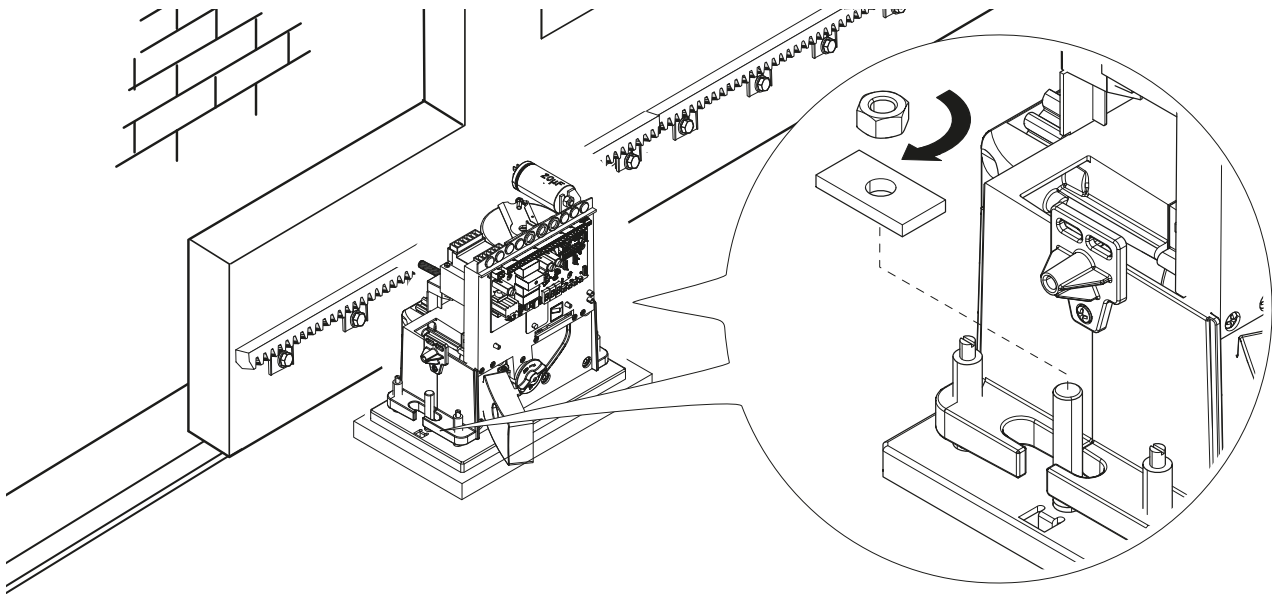

## Determining the travel end points with mechanical limit switches

- 1 Open the gate.
  - 2 Insert the opening limit-switch tab in the rack.
- The spring must trigger the microswitch.
- 3 Fasten the opening limit-switch tab using the grub screws supplied.

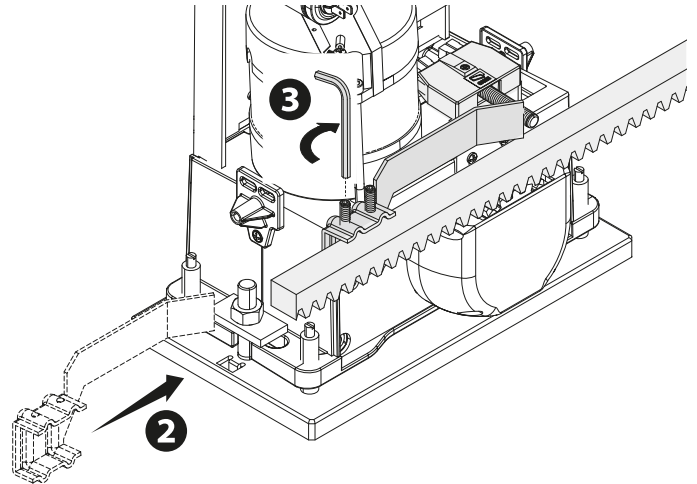
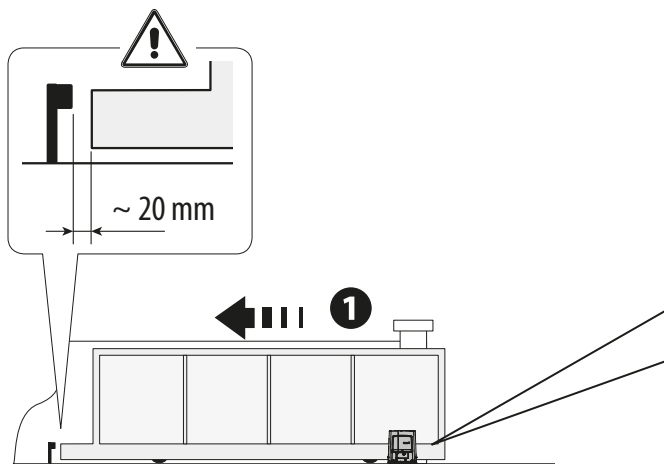

- 4 Close the gate.
  - 5 Insert the closing limit-switch tab in the rack.
- The spring must trigger the microswitch.
- 6 Fasten the closing limit-switch tab using the grub screws supplied.

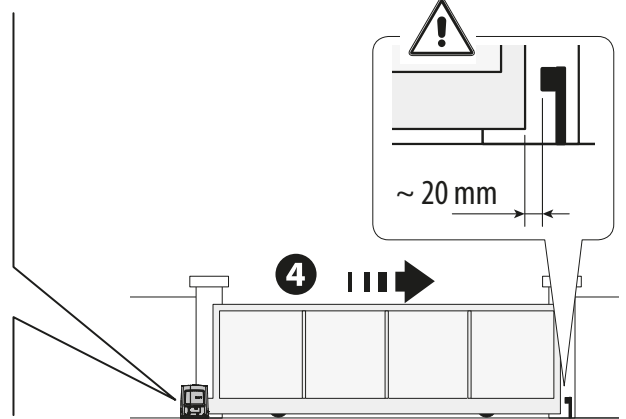
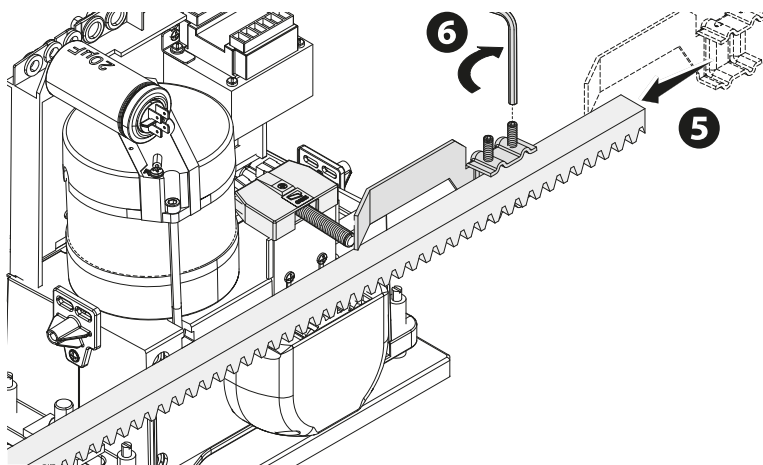

## Passing the electrical cables

 Connect all wires and cables in compliance with the law.

The electrical cables must not touch any parts that may overheat during use (such as the motor and transformer).

 Use cable glands to connect the devices to the control panel. One of these must be used exclusively for the power supply cable.

 Cable glands on the board holder

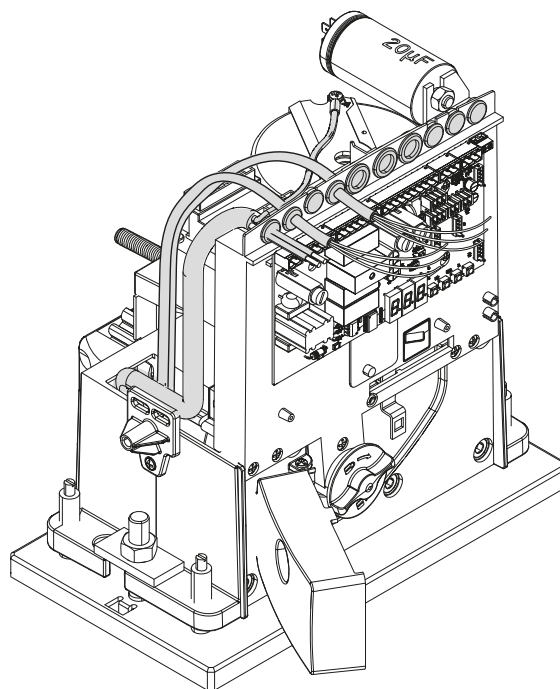
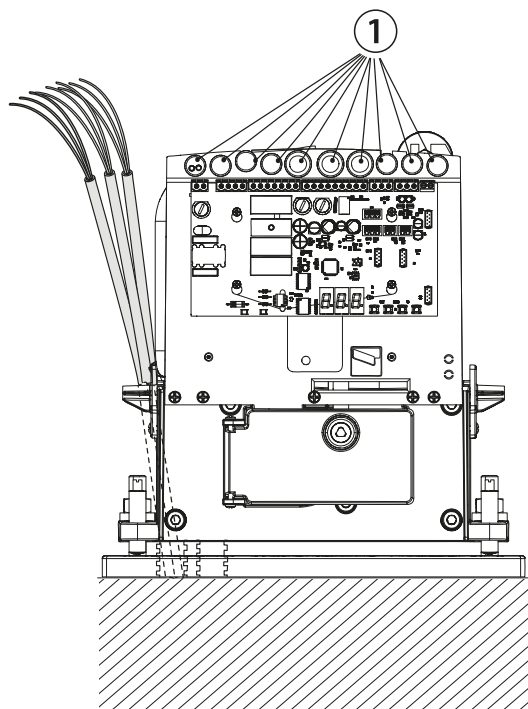

## Power supply

Make sure the mains power supply is disconnected during all installation procedures.

 Before working on the control panel, disconnect the mains power supply and remove the batteries, if any.

### Connecting to the mains (230/120 V AC - 50/60 Hz)

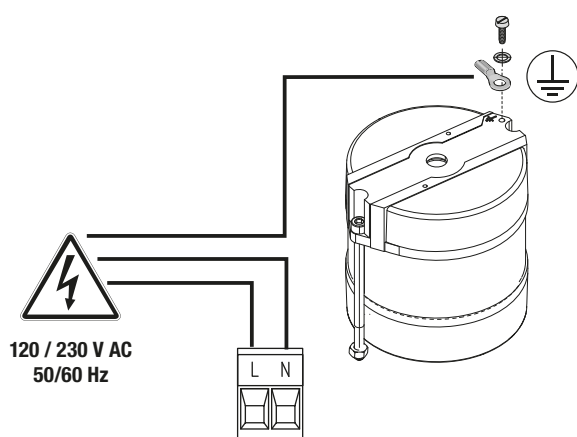

## Connecting accessories

### Power supply output for accessories 24 V

The total power of the outputs listed below must not exceed the maximum output power [Accessories]

Device	Output	Power supply (V)	Maximum power (W)
Accessories	10 - 11	24 AC	20
Passage-open warning light	11 - FC / 11 - FA	24 AC	3

### Power supply output for accessories 230 V

Device	Output	Power supply (V)	Frequency (Hz)	Maximum power (W)
Flashing beacon	W - E1	230 AC	50/60	25
Additional light	W - E1	230 AC	50/60	60

### Power supply output for accessories 24 V

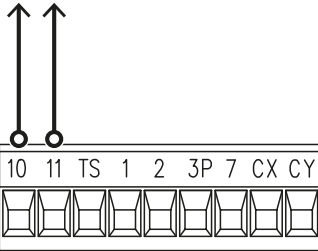

The output normally delivers 24 V AC.

The sum of the power draw for the connected accessories must not exceed 20 W.

### Torque limiter

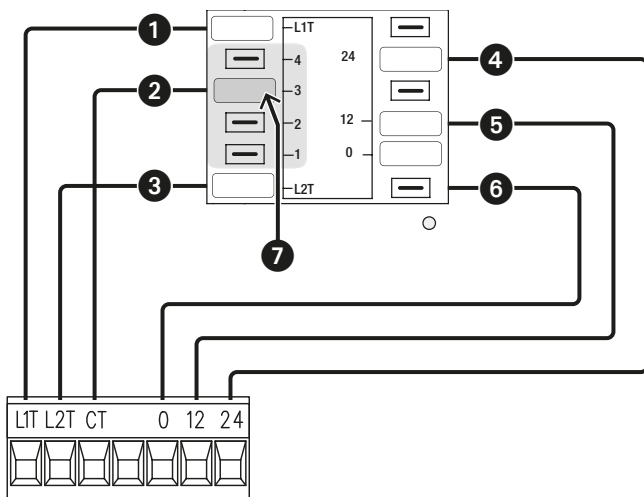

- ❶ White cable
- ❷ Black cable
- ❸ Red cable
- ❹ Blue cable
- ❺ Purple cable
- ❻ Orange cable
- ❼ To vary the motor torque, move the corresponding Faston terminal to one of the four positions; from 1 (minimum) to 4 (maximum).

## Signalling devices

### ❶ Flashing beacon

It flashes when the operator opens and closes.

### ❷ Additional light

It increases the light in the manoeuvring area.

### ❸ Operator status warning light

It indicates that the operator is in the open position.

### ❹ Operator status warning light

It indicates that the operator is in the closed position.

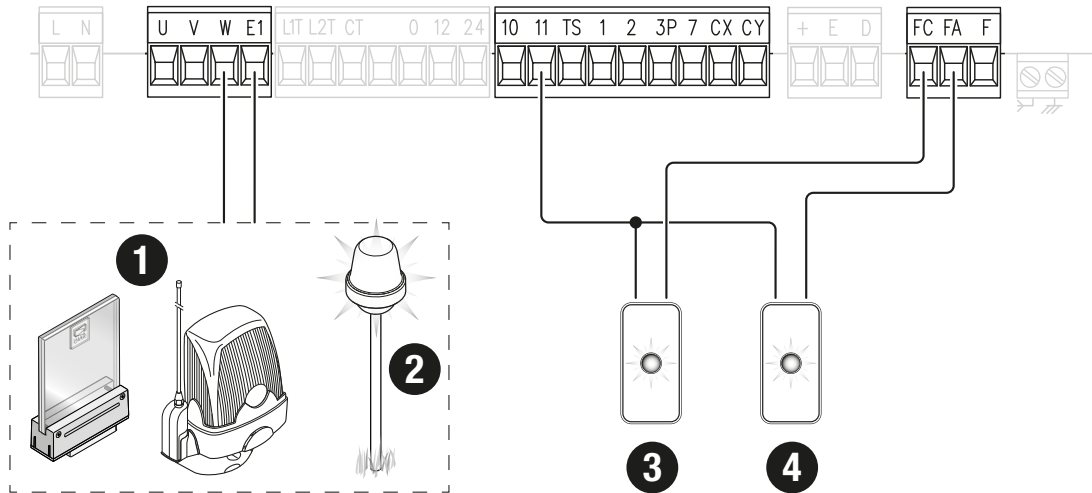

## Command and control devices

- ❶ Keypad selector
- ❷ Card reader
- ❸ Transponder selector switch
- ❹ STOP button (NC contact)

This stops the gate and excludes automatic closing. Use a control device to resume movement.

📖 If the contact is not used, it must be deactivated during programming.

- ❺ Control device (NO contact)

PARTIAL OPENING function

- ❻ Control device (NO contact)

OPEN-CLOSE (step-by-step) or OPEN-STOP-CLOSE-STOP (sequential) function

- ❼ Antenna with RG58 cable

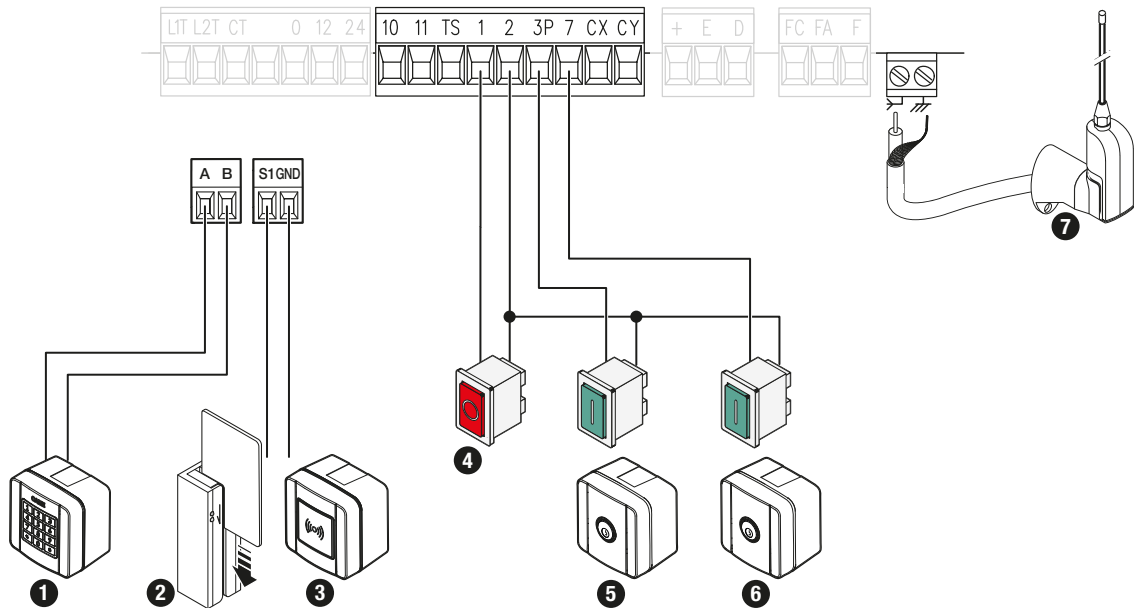

## Safety devices

During programming, configure the type of action that must be performed by the device connected to the input. Connect the safety devices to the CX and/or CY inputs.

📖 If contacts CX and/or CY are not used, they must be deactivated during programming.

### DXR / DLX photocells

Standard connection

### DXR / DLX photocells

Connection with safety test

📖 See function [F5] Safety devices test.

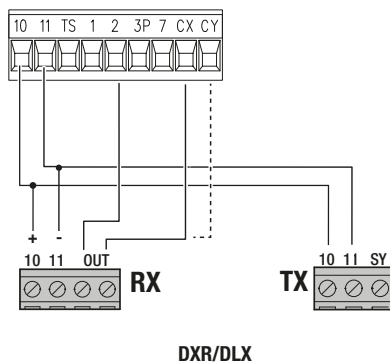

DXR/DLX

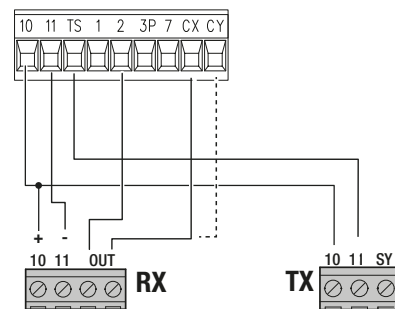

DXR/DLX

## DIR photocells

Standard connection

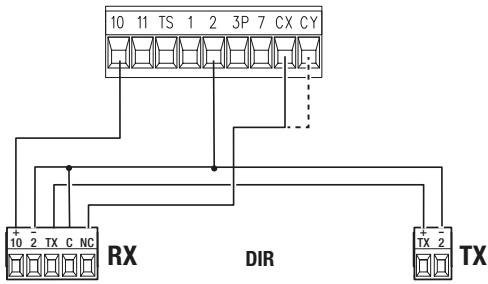

## DIR photocells

Connection with safety test

See function [F5] Safety devices test.

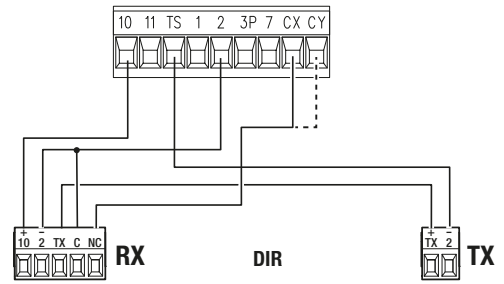

## DFWN sensitive edge

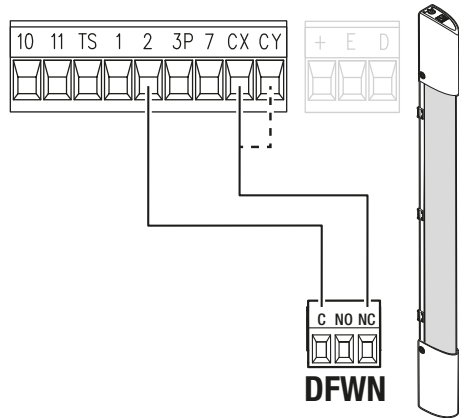

**Programming button functions**

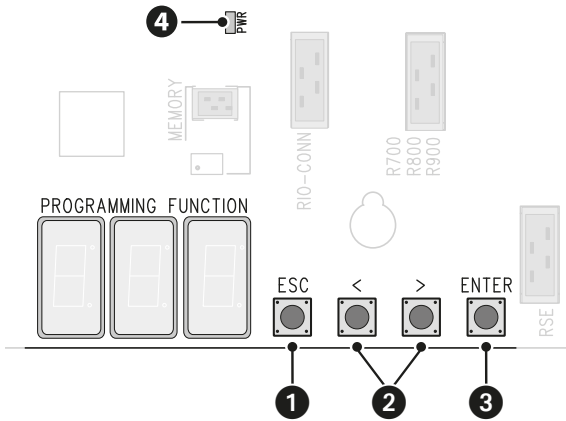

**1 ESC button**

The ESC button is used to perform the operations described below.  
 Exit the menu  
 Delete the changes  
 Go back to the previous screen  
 Stop the operator

**2 < > buttons**

The < > buttons are used to perform the operations described below.  
 Navigate the menu  
 Increase or decrease values  
 Open or close the operator

**3 ENTER button**

The ENTER button is used to perform the operations described below.  
 Access menus  
 Confirm a choice

**4 Power LED**

The LED lights up when the board is powered up.

**Getting started**

Once the electrical connections have been made, proceed with commissioning. Only skilled and qualified staff may perform this operation. Make sure that there are no obstacles in the way. Power up the device and begin programming. Start programming with the functions indicated below.

**F54 Opening direction**

**F1 Total stop**

**A3 Travel calibration**

After powering up the system, the first manoeuvre is always to open the gate; Wait for the manoeuvre to be completed.

Press the **ESC** button or **STOP** button immediately in the event of any faults, malfunctions, strange noises or vibrations, or unexpected behaviour in the system.

If the three display segments are flashing, calibrate the travel.

**Functions menu**

**Total stop**

The function is used to manage operator stops and exclusion of all other commands. When the function is activated, the 2-1 input is used as a normally closed contact.

Use a control device to resume movement.

<b>F1</b>	OFF (Default) ON
-----------	---------------------

## CX input, CY input

Associate a function with the input CX CY

F2	OFF (Default)
F3	C1 = Reopen while closing (photocells) C2 = Reclose while opening (photocells) C3 = Partial stop Only with [F19 - Automatic close] activated. C4 = Obstacle standby (photocells) C7 = Reopen while closing (sensitive edges) C8 = Reclose while opening (sensitive edges) r7 = Reopen while closing (sensitive edge with 8K2 resistor) r8 = Reopen while opening (sensitive edge with 8K2 resistor)

## Safety devices test

The function is used to check that the photocells connected to the selected inputs are operating correctly, after each opening and closing command.

 Run the test by connecting the photocells to the TS terminal [see paragraph on Safety devices].

F5	OFF (Default) 1 = CX 2 = CY 4 = CX+CY
----	--

## Hold-to-run

With the function active, the operator stops moving (opening or closing) when the control device is released.

 When the function is active, it excludes all other control devices.

F6	OFF (Default) ON
----	---------------------



## Command 2-7

The function associates a command to the device connected on 2-7.

F7	0 = Step-by-step (default) - The first command is to open and the second to close. 1 = Sequential - The first command is to open, the second to STOP, the third to close and the fourth to STOP. 2 = Open 3 = Close
----	--

## Command 2-3P

Associate a command to the connected device on 2-3P.

F8	1 = Partial opening (Default)  The partial opening time is set from the function [F71 - Partial opening time].  The degree of partial opening is set as a percentage using the [F36 – Adjusting the partial opening] function. 2 = Open
----	--

## Obstacle with motor stopped

With the function active and the operator stopped, an open or close command is not performed if the safety devices detect an obstacle. The function is active when the passage is closed or open, or after a complete stop.

F9	OFF (Default) ON
----	---------------------

## Encoder

The function activates or deactivates the encoder.

F11	OFF ON (Default)
-----	---------------------



### Sensor type

Use the function to choose the connected control device.

<b>F14</b>	0 = Transponder selector switch 1 = Keypad selector (default)
------------	--

### Additional light

This function allows you to choose the operating mode of the lighting device connected to the output E1 - W.

<b>F18</b>	0 =Flashing beacon (Default) 1 = Cycle light - The lamp stays on during the manoeuvre.  An automatic closing time must be set under [F19 – Automatic closing] to ensure correct operation.  This parameter does not appear if the [F19 - Automatic Close] function is deactivated.
------------	---

### Automatic closure

The function is used to set the time before automatic closure, once the opening travel end point has been reached or once the photocells have caused a partial stop [C3].

 The function does not work if any of the safety devices are triggered when an obstacle is detected, or after a complete stop, or during a power outage.

<b>F19</b>	OFF (Default) From 1 to 180 seconds
------------	--

### Automatic closing after partial opening

The function is used to set the time before automatic closure after a partial opening command has been performed or after the photocells have caused a partial stop [C3].

 The function does not work if any of the safety devices are triggered when an obstacle is detected, or after a complete stop, or during a power outage.

 Do not deactivate the function [F19 - Automatic close].

<b>F20</b>	OFF 1 to 180 seconds (Default 10)
------------	--------------------------------------

### Pre-flashing time

Adjust the time for which the beacon is activated before each manoeuvre.

<b>F21</b>	OFF (Default) 1 to 10 seconds
------------	----------------------------------

### Opening and closing slowdown speed

The function is used to set the opening and closing slowdown speed. The percentage is calculated on the maximum travel speed.

 This function appears only if the [F11 - Encoder] function is active.

<b>F30</b>	OFF 1 = High (Default) 2 = Medium 3 = Low
------------	--

### Travel sensitivity

The function adjusts the obstacle detection sensitivity during the gate travel in percentage terms.

This function appears only if the [F11 - Encoder] function is active.

<b>F34</b>	10% to 100% (Default 100%)  10% = minimum thrust and high obstruction sensitivity 100 % =maximum thrust and low obstruction sensitivity
------------	--

**Slowdown sensitivity**

The function adjusts the obstacle detection sensitivity during slowdown in percentage terms.

 This function appears only if the [F11 - Encoder] function is active.

<b>F35</b>	10% to 100% (Default 100%)  10% = minimum thrust and high obstruction sensitivity 100 % =maximum thrust and low obstruction sensitivity
------------	--

**Adjusting the partial opening**

The function is used to set the partial opening percentage for the gate.

 This function appears only if the [F11 - Encoder] function is active.

<b>F36</b>	10% to 80% (Default 20%)
------------	--------------------------

**Opening slowdown space**

The function is used to set the percentage of the total travel to be used for slowdown during gate opening.

 This function appears only if the [F11 - Encoder] function is active.

<b>F37</b>	5% to 30% (Default 25%)
------------	-------------------------

**Closing slowdown space**

The function is used to set the percentage of the total travel to be used for slowdown during gate closing.

 This function appears only if the [F11 - Encoder] function is active.

<b>F38</b>	5% to 30% (Default 25%)
------------	-------------------------

**Manoeuvre thrust activation**

The function adjusts the increase in thrust torque during gate opening and closing.

<b>F48</b>	OFF (Default) ON
------------	---------------------

**RSE communication**

The function is used to configure the card inserted in the RSE connector.

<b>F49</b>	OFF (Default) 1 = Paired 3 = CRP/CAME KEY
------------	---

**Save data**

The function activates saving user data, timings and configurations to the memory device (memory roll).

 The function is displayed only when a memory roll card is inserted into the control board.

<b>F50</b>	OFF (Default) ON (Run operation)
------------	-------------------------------------

**Read data**

The function activates uploading user data, timings and configurations on the memory device (memory roll). Any configurations already on the electronic board are overwritten.

 The function is displayed only when a memory roll card is inserted into the control board.

<b>F51</b>	OFF (Default) ON (Run operation)
------------	-------------------------------------

### Transferring MASTER-SLAVE parameters

The function is used to share the parameters programmed on the master gate with the slave gate.

 This function appears only if the [F49 – RSE communication] function is active.

<b>F52</b>	OFF (Default) ON
------------	---------------------

### Opening direction

The function is used to set the gate opening direction.

<b>F54</b>	0 = To the left (default) 1 = To the right
------------	---

### CRP address

The function assigns a unique identification code (CRP address) to the control board.

 The function is used where there are multiple operators connected to the same communication BUS using the CRP protocol.

<b>F56</b>	from 1 to 255 (Default 1)
------------	---------------------------

### RSE speed

The function is used to set the remote connection system communication speed on the RSE port.

<b>F63</b>	0 = 1200 bps 1 = 2400 bps 2 = 4800 bps 3 = 9600 bps 4 = 14400 bps 5 = 19200 bps 6 = 38400 bps (default) 7 = 57600 bps 8 = 115200 bps
------------	--

### RIO ED T1 and RIO ED T2

The function is used to configure a wireless safety device.

 The function only appears if the RIO CONN interface board is present.

<b>F65</b>	OFF (Default)
<b>F66</b>	P0 = It stops the gate and excludes automatic closing. Use a control device to resume movement. P7 = Reopen while closing. P8 = Reclose while opening.

### RIO PH T1 and RIO PH T2

The function is used to configure a wireless safety device.

 The function only appears if the RIO CONN interface board is present.

<b>F67</b>	OFF (Default)
<b>F68</b>	P1 = Reopen while closing. P2 = Reclose while opening. P3 = Partial stop. Only with [Automatic close] activated. P4 = Obstacle standby.

### Partial opening time

The function is used to adjust the gate opening time.

<b>F71</b>	5 to 40 seconds (Default 5)
------------	-----------------------------

**New user**

The function is used to register up to a maximum of 250 users and assign a function to each one.

 The operation can be carried out by using a transmitter or another control device. The boards that manage the control devices (AF - R700 - R800) must be inserted into the connectors.

<b>U1</b>	<p>1 = Step-by-step - The first command is to open and the second to close.            2 = Sequential - The first command is to open, the second to STOP, the third to close and the fourth to STOP.            3 = Open            4 = Partial opening</p> <p>Choose the function to be assigned to the user.            Press ENTER to confirm.</p> <p>The free position in the memory is shown intermittently for a maximum of 10 seconds. During this phase, send the code from the control device.            Repeat the procedure to add other users.</p>
-----------	---

**Remove user**

The function is used to remove one of the registered users.

<b>U2</b>	<p>Use the arrows to choose the number associated with the user you want to remove.            Alternatively, the control device associated with the user you want to remove can be activated.            Press ENTER to confirm.</p> <p> "CLR" will appear to confirm deletion.</p> <p>No. 1 &gt; 250</p>
-----------	---

**Remove all**

The function is used to remove all registered users.

<b>U3</b>	<p>OFF (Cancel operation)            ON (Run operation)</p>
-----------	---

**Radio decoding**

The function is used to choose the type of radio coding for the transmitters enabled to control the operator.

 If you choose [Rolling code] or [TW key block], any transmitters with a different type of radio coding saved previously will be deleted.

<b>U4</b>	<p>1 = All decoding (default)            2 = Rolling code            3 = TW key block</p>
-----------	---

**Motor type**

The function is used to set the type of gearmotor installed.

<b>A1</b>	<p>1 = BX704            2 = BX708</p>
-----------	---

**Travel calibration**

The function is used to start travel self-learning.

 This function appears only if the [F11 - Encoder] function is active.

<b>A3</b>	<p>OFF (Cancel operation)            ON (Run operation)</p>
-----------	---

**Parameter reset**

Restore factory settings except for the functions: [Radio decoding], [Motor type] and the settings related to travel calibration.

<b>A4</b>	<p>OFF (Cancel operation)            ON (Run operation)</p>
-----------	---

## Manoeuvre counter

The function is used to view the number of operator manoeuvres.

<b>A5</b>	001 = 100 manoeuvres 010 = 1000 manoeuvres 100 = 10000 manoeuvres 999 = 99900 manoeuvres CSI = Maintenance work
-----------	---

## FW version

The function is used to display the firmware version.

**H1**

## Import/export data

Save user data and system configuration data on a MEMORY ROLL card.

The stored data can be reused for another control board to configure another system in the same way.

**⚠** Before inserting and removing the MEMORY ROLL card, DISCONNECT THE MAINS POWER SUPPLY TO THE LINE.

- 1 Insert the MEMORY ROLL card into the corresponding connector on the control board.
- 2 Press the "Enter" button to access programming.
- 3 Use the arrows to choose the desired function.

**📖** The functions are displayed only when a MEMORY ROLL card is inserted.

### - Save data

The function activates saving user data, timings and configurations to the memory device (memory roll).

### - Read data

The function activates uploading user data, timings and configurations on the memory device (memory roll). Any configurations already on the electronic board are overwritten.

**📖** Once the data have been saved and loaded, remove the MEMORY ROLL card.

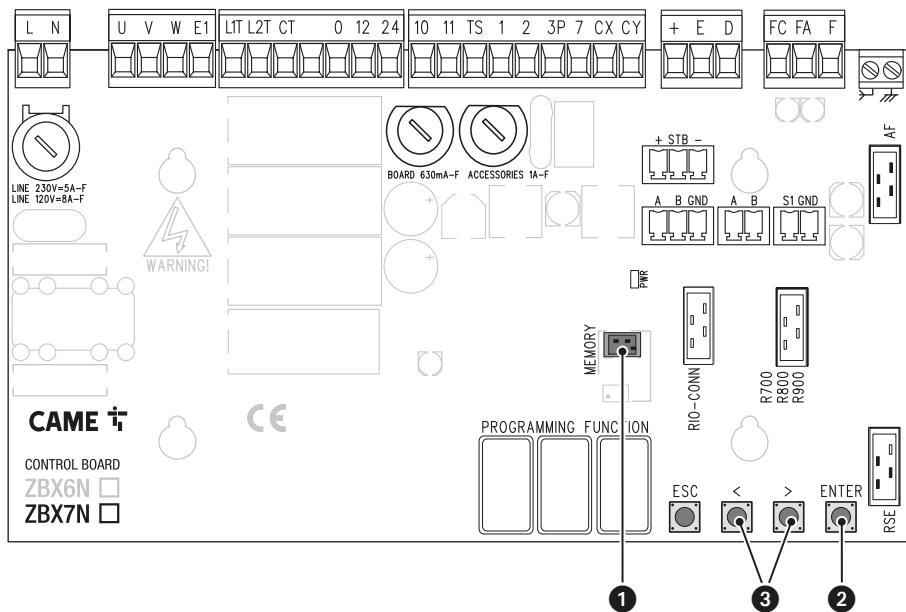

## ERROR MESSAGES

E1	Calibration error
E2	Adjustment error
E3	Encoder failure error
E4	Service test failure error
E7	Operating time error
E8	Open release-hatch error Check that the accessories fuse is not blown.
E9	Obstacle detected during closing
E10	Obstacle detected during opening
E11	The maximum number of obstacles detected consecutively has been exceeded
E14	Communication error
E15	Incompatible transmitter error
E17	Wireless system communication error
E18	Wireless system not configured error

## FINAL OPERATIONS

 Before closing up the casing, check that the cable inlets are sealed to stop insects getting in and to prevent damp.

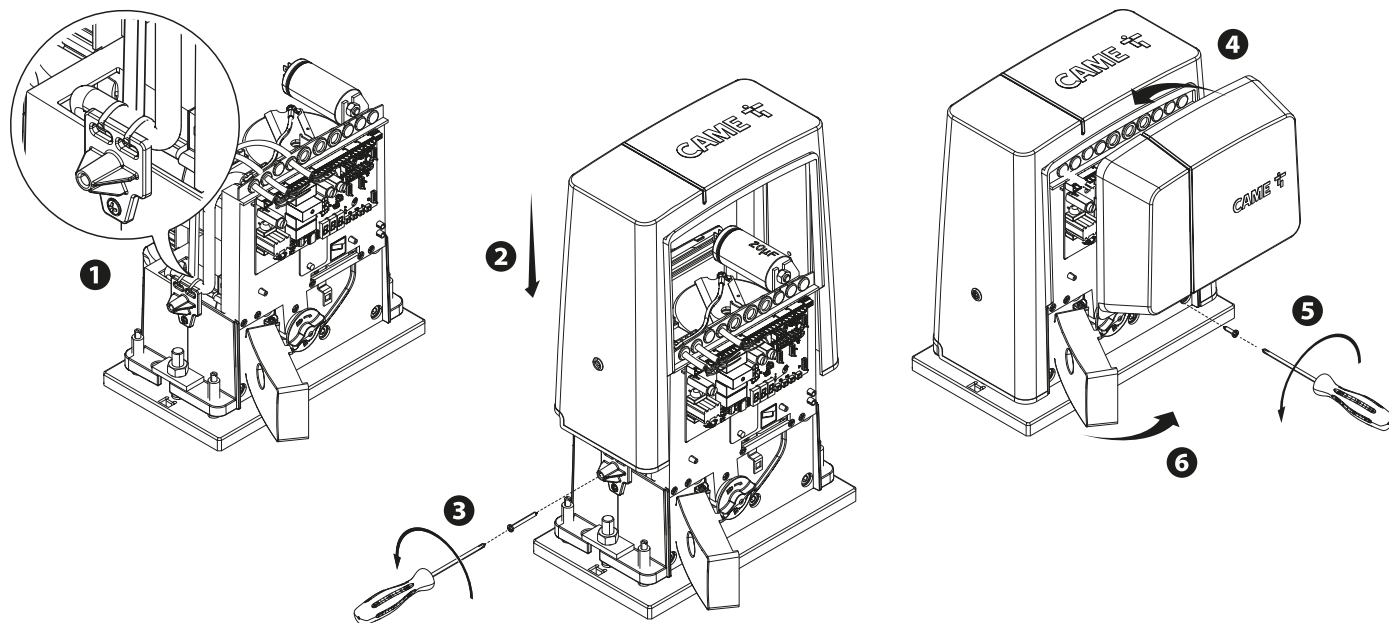

## PAIRED OPERATION

Two connected operators are controlled with one command.

### Electrical connections

Connect the two electronic boards with a UTP CAT 5 cable.

Insert an RSE card into both control boards.

Connect up the electrics for the devices and accessories.

The devices and accessories must be connected to the control board which will be set as the MASTER.

For information on connecting the electrics for the devices and accessories, please see the "ELECTRICAL CONNECTIONS" section.

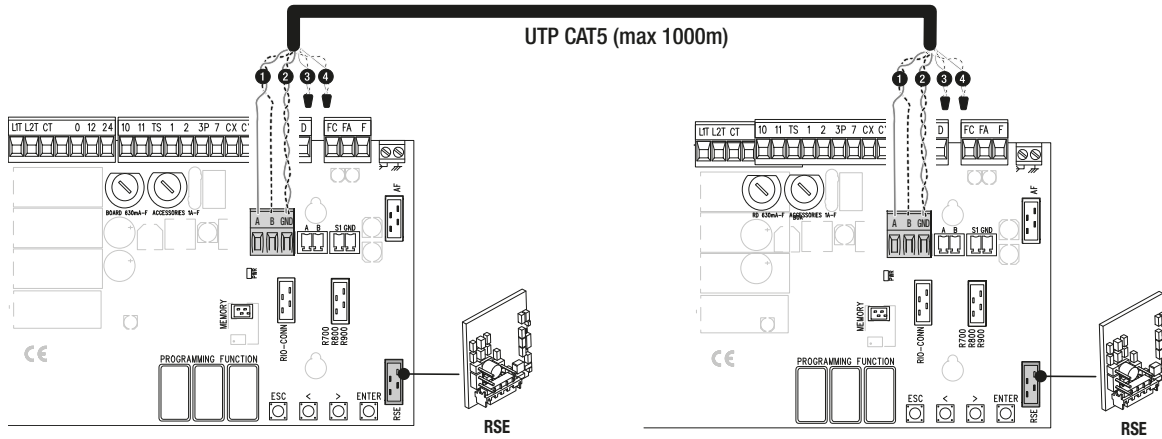

### Programming

All programming operations described below must be performed only on the control board set as the MASTER.

F49 RSE communication

F54 Opening direction

F52 Transferring MASTER-SLAVE parameters

A3 Travel calibration

### Saving users

All save user operations must be performed only on the control board set as the MASTER.

### Operating modes

❶ PARTIAL OPENING command

❷ STEP-BY-STEP or OPEN ONLY command

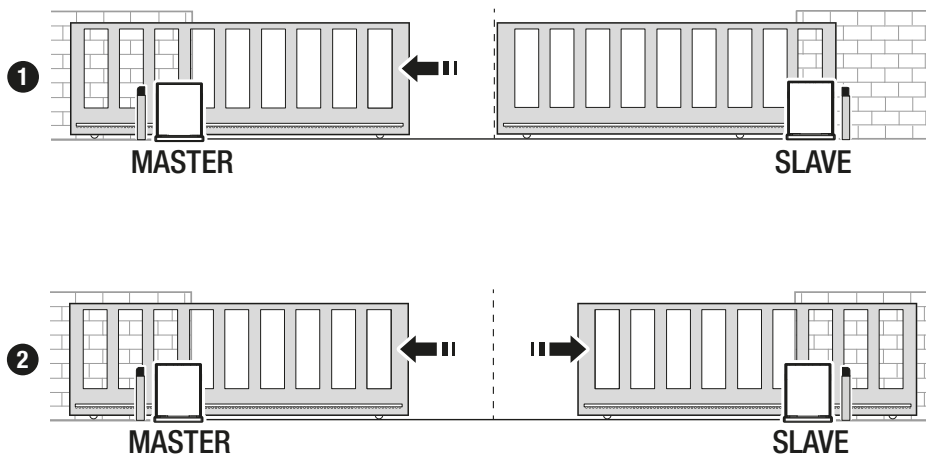

MCBF		
Models	BX704	BX708
14 m - 400 kg	150000	-
14 m - 800 kg	-	150000
Installation in windy area	-15%	-15%

 The percentages indicate how much the number of cycles should be reduced in relation to the type and number of accessories installed.

 Before carrying out any cleaning or maintenance, or replacing any parts, disconnect the device from the power supply.

 This document informs the installer of the checks that must be carried out during maintenance.

 If the system is not used for long periods of time, e.g. for installations at sites with seasonal closures, disconnect the power supply. When the power supply is reconnected, check the system is working correctly.

 For information on correct installation and adjustments, please see the product installation manual.

 For information on choosing products and accessories, please see our product catalogue.

 Every 10,000 cycles and, in any case, every 6 months of operation, you must perform the maintenance work indicated below.

Perform a general and complete check of the tightness of the nuts and bolts.

Grease all of the moving mechanical parts.

Check the warning and safety devices are working properly.

Check for any wear on the moving mechanical parts and check that they are working properly.

Check the release mechanism is working efficiently by performing a manoeuvre with the leaf free. The gate leaf must not be obstructed.

Check the cables are intact and connected correctly.

Check and clean the track guide and rack.



**CAME** 

**CAME.COM**

**CAME S.P.A.**

Via Martiri della Libertà, 15  
31030 Dosson di Casier  
Treviso - Italy  
Tel. (+39) 0422 4940  
Fax (+39) 0422 4941