

**Control panel
for 230 V gearmotors**

FA01883-EN



ZA3P

INSTALLATION MANUAL



IMPORTANT SAFETY INSTRUCTIONS WHEN INSTALLING



Follow all of these instructions as improper installation may lead to be hazardous to people. Before continuing also read the general precautions for users included in the operator's package.

- This control panel is expressly designed to be assembled to partly-completed machinery or equipment so as to build machinery as regulated by European Directive 2006/42/CE. The final installation must conform to Directive 2006/42/CE and to any harmonized reference standards. Given these considerations, all operations provided in this manual must be performed by skilled, qualified staff.
- This product should only be used for the purpose for which it was explicitly designed. Any other use is dangerous. CAME S.p.A. is not liable for any damage caused by improper, wrongful and unreasonable use.
- Before installing the control panel, make sure that the guided part is in proper mechanical order, that it opens and closes properly and that it is balanced - otherwise, do not continue until you have first complied with all safety provisions.
- Make sure that people cannot be entrapped between the guided and fixed parts, when the guided part is set in motion.
- The control panel cannot automate any guided part that includes a pedestrian gate, unless the latter can be enabled only when the pedestrian gate is secured.
- Make sure the anchoring spot is clear of any potential impacts, that the anchoring surfaces are solid, and that suitable screws, wall plugs, and the such are used for the type of surface.
- Laying the cables, installation and testing must follow state-of-the-art procedures as dictated by regulations
- Check that the temperature ranges given and those of the location match.
- Demarcate the entire site to prevent unauthorized personnel to enter; especially children and minors.
- Use proper means of protection to prevent any mechanical hazards from people caught in the movement of the automated operator. Any residual risks must be highlighted by fitting pictograms, in clear view. These must then be explained to the end user of the machinery.
- Fit, in plain sight, the machine's ID plate when the installation is complete
- All command and control devices must be fitted so that they are clearly visible, at a proper safety distance from the maneuvering guided-part and where they cannot be reached through said guided part.
- Unless we are talking about key-pad selectors, key-switch selectors, transponder selectors, and so on, the maintained-action control devices must be fitted at least 1.5 m above ground, where they cannot be reached by the general public.
- The manufacturer declines any liability if non-original parts are used. In which case the warranty will cease to

be effective. • All maintained-action switches that are connected to the control panel must be positioned so that the maneuvering area is completely visible from the switches, yet far enough away from any moving parts. • Make sure that the operator has been properly adjusted and that any associated safety and protection devices, as well as the gearmotor's manual release, are working properly. • If the power-supply cable is damaged, it must be replaced by the manufacturer or by the licensed technical-assistance center or by duly trained, skilled staff, to prevent any risks. • During all phases of the installation make sure you have cut off the mains power source. • The electrical cables must run through corresponding tubes or conduits to ensure suitable protection against mechanical damage and they must not come into contact with parts that could heat up during use. • Make sure you have set up a suitable dual pole cut off device along the power supply that is compliant with the installation rules. It should completely cut off the power supply according to category III surcharge conditions. • If the control panel is used for automating guided parts in residential settings, permanently fit the entrapment-hazard-warning signage, so that it is clearly visible or close enough to all command and control devices. After installing, make sure that the operator is properly adjusted and that the guided part, in case it touches any object that is 50 mm high off the ground, inverts its movement or that the object may easily be removed (for operators that have built-in anti-entrapment systems that depend on coming into contact with the lower edge of the guided part). Also make sure that the guided part does not extend onto any public pedestrian passages or onto the street. • Store this manual inside the technical folder, along with the installation manuals of the other devices in the system. Remember to hand over to the end users all the operating manuals of the products that make up the final machinery.



The product, in its original packaging supplied by the manufacturer, must only be transported in a closed environment (railway carriage, containers, closed vehicles).

If the product malfunctions, stop using it and contact customer services at <https://www.came.com/global/en/contact-us> or via the telephone number on the website.

The manufacture date is provided in the production batch printed on the product label. If necessary, contact us at <https://www.came.com/global/en/contact-us>.

The general conditions of sale are given in the official CAME price lists.

KEY

-  This symbol shows which parts to read carefully.
-  This symbol shows which parts describe safety issues
-  This symbol shows which parts to tell users about.

The measurements, unless otherwise stated, are in millimeters.

DESCRIPTION

Multi-feature control panel for swing gates, with manageable limit-switches and slow-down speed adjusting.

The control devices and accessories run on 24V.

 The accessories must not exceed 20W overall.

All the connections are quick-fuse protected (see table).

The control board provides and controls the following functions:

- automatic closing following an opening command;
- pre-flashing by the movement indicator-light;
- obstruction detection when gate is not moving at any point;
- adjustment of the connected operator's torque;
- opening final jolt; - fixed slow-down of 10 seconds with adjustable speed;
- manageable limit-switches:

The settable control modes are:

- opening/closing;
- opening/closing in maintained action;

- partial opening; - total stop.

The photocells, after detecting an obstruction, may trigger:

- reopening if the gate is closing;
- the closing or partial stop if it is opening;
- partial stop if gate is opening.

Specific trimmers regulate:

- the automatic closing's intervention time;
- gearmotor M2's closing delay;
- the operating time.

You can also connect:

- gate-open warning lights;
- cycle lights;
- electric lock.

Intended use

Model	Operator
ZA3P	ATI - FAST - FERNI - FROG - KRONO

 Any installation and/or use other than that specified in this manual is forbidden.

Technical data

Type	ZA3P
Protection rating (IP)	54
Power supply (V - 50/60 Hz)	230 AC
Absorption when idle (mA)	60
Max. power* (W)	750
Casing material	ABS
Operating temperature (°C)	-20 to +55
Insulation class	
Storage temperature** (°C)	-25 to +70
Average life*** (cycles)	100000

(*) Overall power of the connected motors

(**) Before installing the product, keep it at room temperature where it has previously been stored or transported at a very high or very low temperature.

(***) The average product life is a purely indicative estimate. It applies to compliant usage, installation and maintenance conditions. It is also influenced by other factors, such as climatic and environmental conditions.

Fuse table

To protect	Fuse type
Line (LINE-FUSE)	5 A-F
Card()CONTROL BOARD	1 A-F
Accessories()ACCESSORIES	1.6 A-F
Electriclock (LOCK)	3.15 A-F

Dimensions

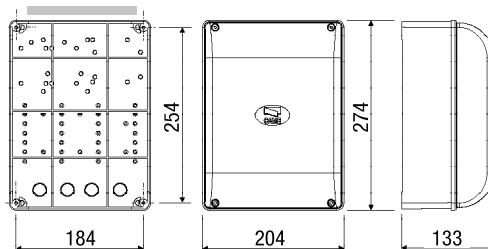

Description of parts

- | | | | |
|----|-------------------------------|-----|------------------------------|
| 1. | Connection terminals | 8. | Time setting trimmer |
| 2. | Control board fuse | 9. | Features selectors |
| 3. | Fuse for control devices | 10. | AF radio frequency card slot |
| 4. | Accessories fuse | 11. | 24 V warning LED |
| 5. | Electric-lock fuse | 12. | Transformer |
| 6. | LED programmazione | 13. | Condensers* |
| 7. | Radio code memorizing buttons | | |

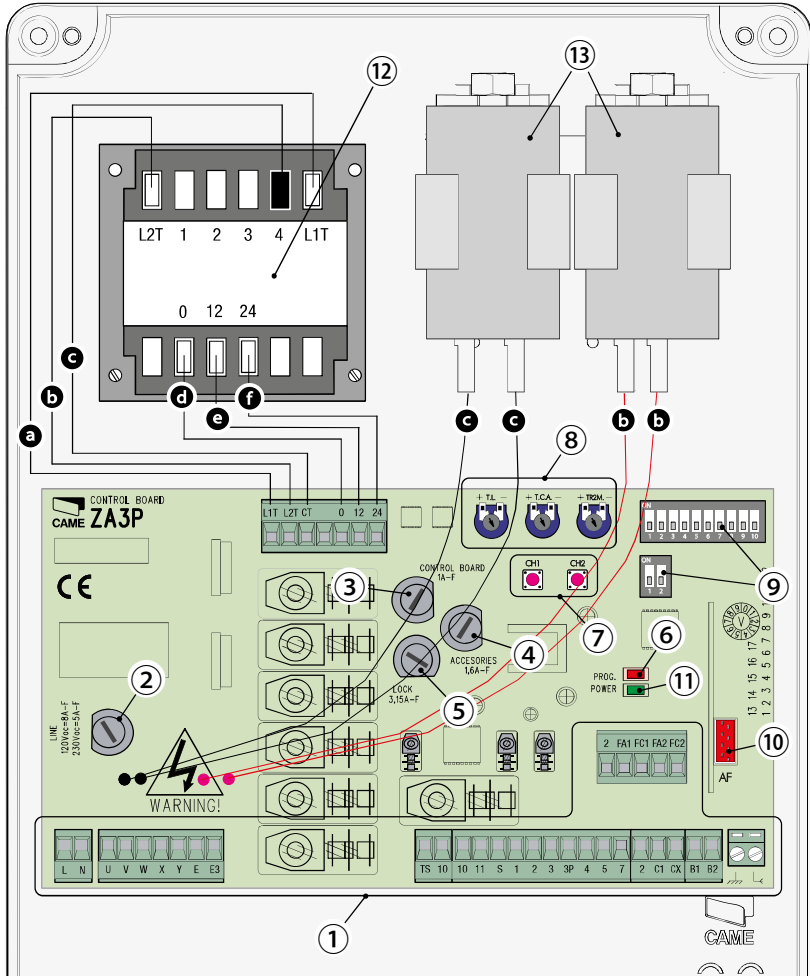

***13** Included in the package containing the 230 V FROG geamotor. Connect them to the black cables (M1) and the red cables (M2), as set up on the card. if pairing with Aiü, Fast, Femi and Krono geamotors, these remain unused (the condensers are connected internally).

Colour of the transformer and condenser cables: **a** white; **b** red; **c** black; **d** orange; **e** purple; **f** light blue.

Cable type and minimum section

Connection	cable length	
	< 20 m	20 < 30 m
Control panel power-supply	3G x 1.5 mm ²	3G x 2.5 mm ²
Motor power supply	4G x 1.5 mm ²	4G x 2.5 mm ²
Signaling devices	2 x 0.5 mm ²	
Command and control devices	2 x 0.5 mm ²	
Safety devices (photocells)	2 x 0.5 mm ²	

📖 When operating at 230 V and outdoors, use H05RN-F-type cables that are 60245 IEC 57 (IEC) compliant; whereas indoors, use H05VV-F-type cables that are 60227 IEC 53 (IEC) compliant. For power supplies up to 48 V, you can use FROR 20-22 II-type cables that comply with EN 50267-2-1 (CEI).

For the Encoder use 2402C 22AWG-type cables up to 30 m.

For a CRP connection use UTP CAT5-type cables up to 1,000 m.

Use RG58 cable up to 10 m long to connect the antenna.

📖 If cable lengths differ from those specified in the table, establish the cable sections depending on the actual power draw of the connected devices and according to the provisions of regulation CEI EN 60204-1.

📖 For multiple, sequential loads along the same line, the dimensions on the table need to be recalculated according to the actual power draw and distances. For connecting products that are not contemplated in this manual, see the literature accompanying said products

INSTALLATION

Tools and materials

Make sure you have all the tools and materials you will need for installing in total safety and in compliance with applicable regulations. The figure shows some of the equipment installers will need.



Fastening the control panel

1 Fasten the control panel in a protected area; use rounded cross head screws with maximum 6 mm diameter. maximum 6 mm diameter.

2 Perforate the punched holes.

📖 The holes have different diameters: 23, 29 and 37 mm.

⚠️ Be careful not to damage the control board inside the casing.

3 Enter the cable gland with the corrugated tubes for threading the electrical cables.

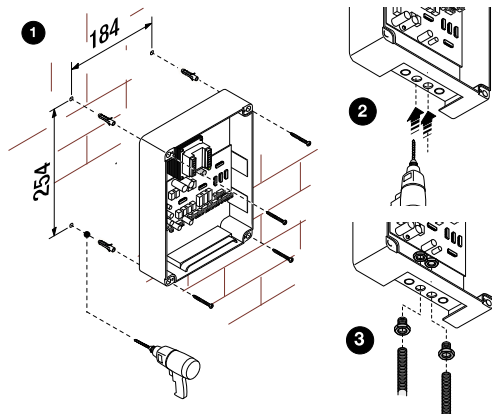

Input voltage

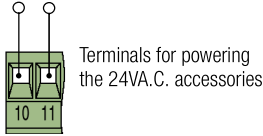
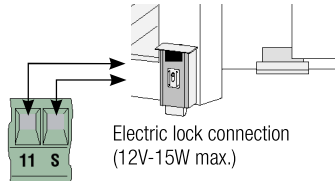
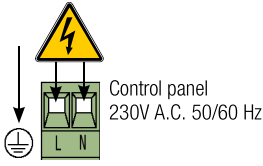

Gearmotor

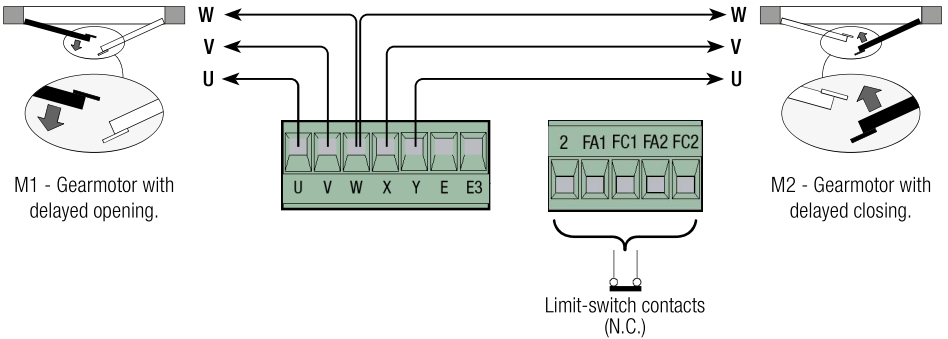

M1 - Gearmotor with delayed opening.

M2 - Gearmotor with delayed closing.

Came gearmotors standard set opening scheme.

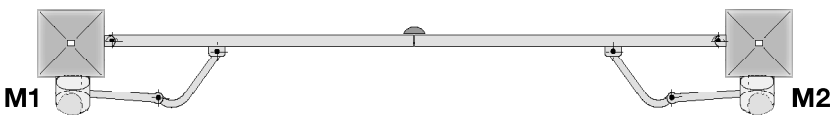

With gates with only one leaf, connect the gearmotor to W X Y (M2) regardless of the side it is fitted on (for FRÖG, if necessary, invert connections X and Y);

Warning and lighting devices

Gate open warning-light

- For warning that the gate is open. It stops flashing when the gate closes.

Movement warning flashing-light

- It flashes when the gate is opening and closing.

Courtesy light.

- It stays on for a fixed time of 5 minutes from the moment in which the gate-leaves start their maneuver.

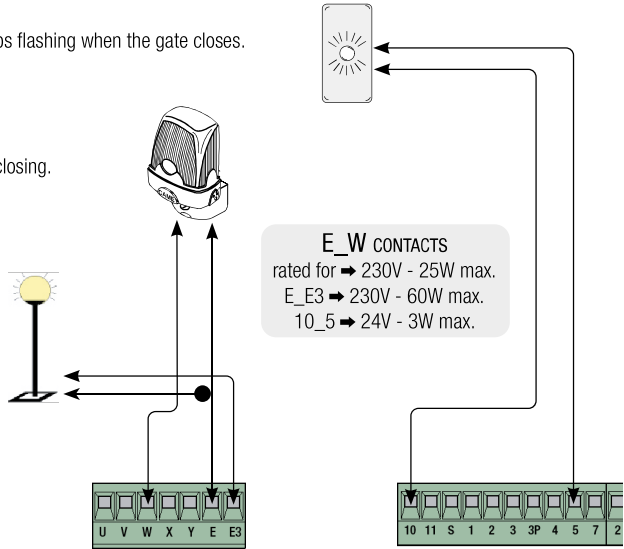

Command and control devices

Stop button (N.C. contact).

- For commanding the gate to stop while excluding the automatic-closing time cycle. To resume movement, press a button on the control or the transmitter button. **If unused, short-circuit terminals 1-2.**

Key-switch selector and/or opening button (N.O. contact).

- For commanding the gate to open.

Key-switch selector and/or partial opening button (N.O. contact).

- For commanding the partial opening of a leaf (M2).) for pedestrian passage.

Key-switch selector and/or closing button (N.O. contact).

- For commanding the gate to stop.

Key-switch selector and/or command button (N.O. contact).

- For commanding the opening and closing of the gate. By pressing the button or turning the selector key, the gate inverts its movement or stops, depending on the selection made on the DIP-switches (see selecting functions, DIP-switches 2 and 3).

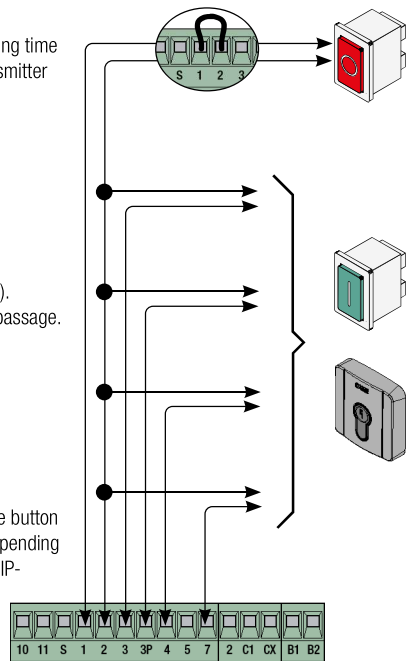

Safety devices

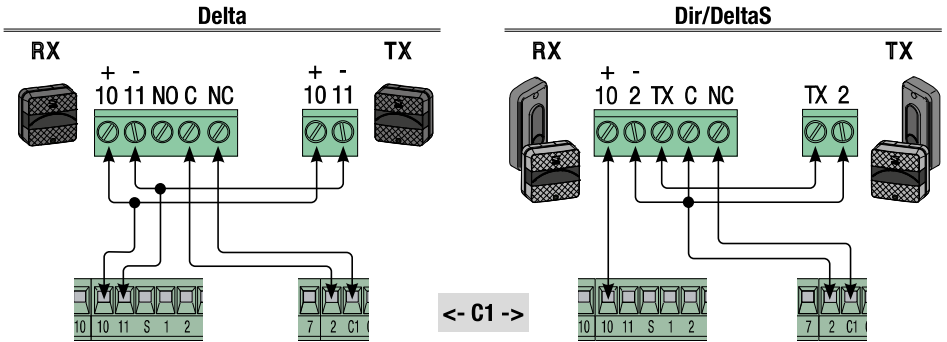

Connection for **reopening during closing** (N.C. contact). - With safety device such as photocells, sensitive safety-edges and other devices. During closing, the contact triggers an inversion of movement until the gate is completely open.

If unused, short-circuit 2-C1.

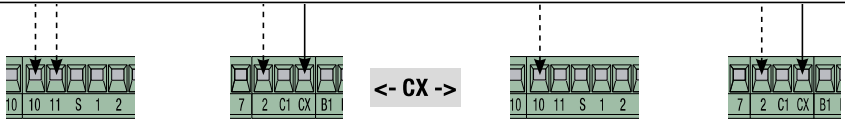

with DIP-switch 8 OFF - DIP-switch 2 OFF (Selector) **B**

Connection for **reclosing during opening** (N.C. contact).
- With safety device such as photocells, sensitive safety-edges and other devices. During the opening phases, the contact triggers an inversion of movement until the gate is completely closed.

with DIP-switch 8 OFF - DIP-switch 2 ON (Selector) **B**

Partial-stop connection (N.C. contact). - With safety device such as photocells, sensitive safety-edges and other devices. Stops movement and sets up for automatic closing.

If unused, disable input CX with DIP-switch 8 set to ON.

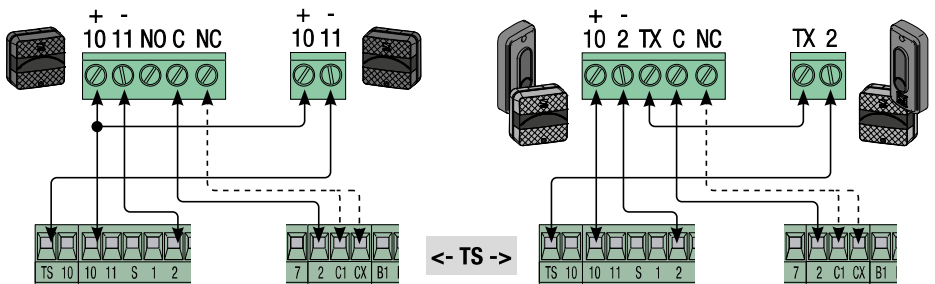

with DIP-switch 10 ON

Safety-test function **connection** - At each opening or closing command, the card verifies the photocells' efficiency. Any malfunction in the photocells is signalled by the flashing LED on the control board, and cancels any command from the radio transmitter or from the button. **PROG**
IMPORTANT: When the safety-test function is enabled, at least one pair of photocells must be connected to "reopen during closing" (C1).

Functions selection

Selector A

- 1 ON Automatic closing enabled (1 OFF-disabled);
- 2 ON "Open-stop-close-stop" with button (2-7) and radio-control (AF card fitted) enabled;
- 2 OFF "Open-close" with button (2-7) and radio control (AF card fitted) enabled; 3 ON "Only open" and radio control (AF card fitted) enabled (3 OFF-disabled);
- 4 ON Pre-flash when opening and closing enabled (4 OFF- disabled);
- 5 ON Obstruction detection enabled (5 OFF-disabled);
- 6 OFF "Maintained action" (excludes the radio control from functioning) disabled (6 ON - enabled);
- 7 ON Final jolt enabled; at each opening and closing command, the gate leaves jolt inwards for a second, to help release the electric lock connected to terminals 11-S. It is active only if the leaves are closed at the end of the operating time, or at the first maneuver after powering up the system (7 OFF - disabled);
- 8 OFF Terminal CX enabled (8 ON - disabled);
- 9 ON Ten-second slow-down disabled (9 OFF - enabled);
- 10 ON Photocell test enabled (10 OFF disabled).

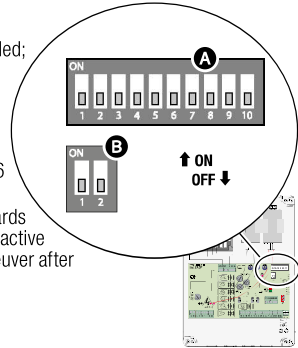

Selector B

- 1 ON Limit switches enabled (1 OFF - disabled);
- 2 OFF CX with close while opening function;
- 2 ON CX with partial stop function, only with selector switch A DIP 1 set to ON.

Trimmer adjusting

- OT** = To set the operating time to a minimum of 10 seconds and a maximum of 120 seconds.
- ACT** = To set the automatic closing time from a minimum of 1 second to maximum of 120 seconds.
- TR2M** = To set the closing delay on Motor 2 from a minimum of 0 seconds to a maximum of 15 seconds, and simultaneously the partial opening from minimum of 0 seconds to a maximum of 30 seconds.

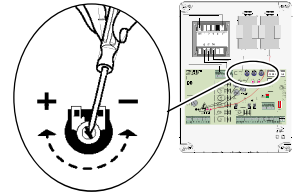

Adjusting slow-down speed

For adjusting the slow-down speed (perform procedures only when gate is stopped):

- set DIP-switch 6 to ON;
- by pressing CH 1, the red **PROG** LED will show the set slow-down speed (see table);
- by again pressing CH 1 it shifts to the next speed;
- confirm the choice by pressing CH 2;
- reset DIP-switch 6 to OFF.

Flashing in quick succession	Slow-down speed
1	minimum
2	medium
3	maximum

Adjusting the motor torque

To vary the motor torque, move the show faston to one of the four positions:

1 min., 4 max..

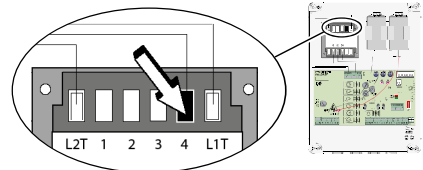

Antenna and AF radiofrequency card

- ❶ Connect the RG58 antenna-cable to the corresponding terminals.
- ❷ Fit the radio-frequency card into the slot on the control board AFTER CUTTING OFF THE MAINS POWER SUPPLY. N.B.: The control board recognizes the radiofrequency card only when it is powered up.

Possible connection to a second operator that can be activated from the second channel on the radio circuit (N.O. contact).
Contact rated for: 5A-24 V DC

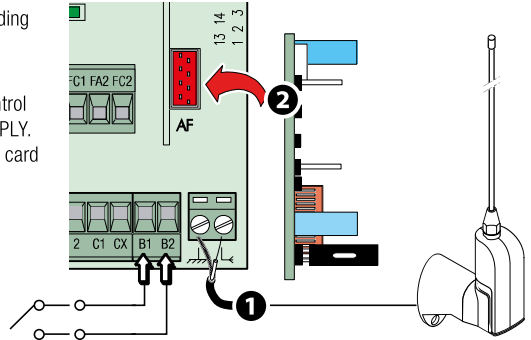

Memorization (max. 25 different transmitters)

- CH1** = Channel for direct commands to a features of the gearmotor's control board ("open only / " open-close-invert" command or "open-stop-close-stop", depending on the selection made on DIP-switches 2 and 3).
- CH2** = Channel for direct command to an accessory device connected to B1-B2.

- ❶ Keep the **CH1** button pressed on the control board (the LED will flash), send the code by pressing the transmitter's **❷** button, the LED will stay on to confirm that the data has been saved.

Do the same with the **CH2** button, and associated it to another of the transmitter's buttons.

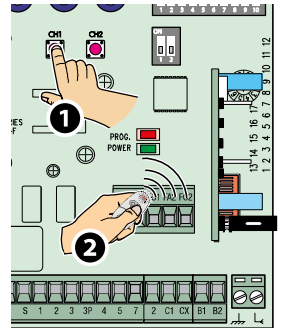

Totally cancelling the memory

Simultaneously keep pressed buttons CH1 and CH2 for over five seconds; when the LED stays lit, all of the radio control will be cancelled. **PROG**

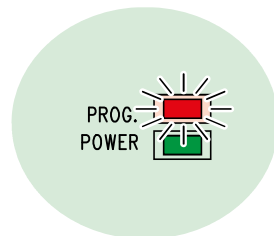
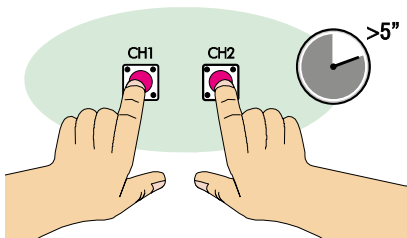

FINAL OPERATIONS

Fastening the cover

Once the electrical connections and set up are done, fit the cover and fasten it using the supplied screws.

 Before closing up the casing, check that the cable inlets are sealed to stop insects getting in and to prevent damp.

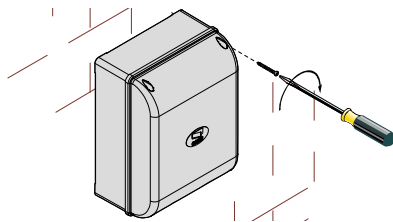

DISMANTLING AND DISPOSAL

Always make sure you comply with local laws before dismantling and disposing of the product. The packaging materials (cardboard, plastic, and so on) should be disposed of as solid household waste, and simply separated from other waste for recycling.

Whereas other components (control boards, batteries, transmitters, and so on) may contain hazardous pollutants. These must therefore be disposed of by authorized, certified professional services.

DISPOSE OF RESPONSIBLY!

REFERENCE REGULATIONS

CAME SpA declares that this product complies with the current directives at the time it is manufactured.

The contents of this manual may change, at any time, and without notice.

CAME 

CAME.COM

CAME S.P.A.

Via Martiri Della Libertà, 15
31030 Dosson di Casier - Treviso - Italy
tel. (+39) 0422 4940 - fax. (+39) 0422 4941
info@came.com - www.came.com