

# Operator for swing gates

FA02021-EN



## AX3024/AX5024

INSTALLATION MANUAL

EN English



**WARNING!**  
**important safety instructions for people:**  
**READ CAREFULLY!**



**PREMISE**

• THIS PRODUCT SHOULD ONLY BE USED FOR THE PURPOSE FOR WHICH IT WAS EXPLICITLY DESIGNED. ANY OTHER USE IS DANGEROUS. CAME S.p.A. IS NOT LIABLE FOR ANY DAMAGE CAUSED BY IMPROPER, WRONGFUL AND UNREASONABLE USE • KEEP THESE WARNINGS TOGETHER WITH THE INSTALLATION AND OPERATION MANUALS THAT COME WITH THE OPERATOR.

**BEFORE INSTALLING**

*(CHECKING WHAT'S THERE: IF SOMETHING IS MISSING, DO NOT CONTINUE UNTIL YOU HAVE COMPLIED WITH ALL SAFETY PROVISIONS)*

• CHECK THAT THE AUTOMATED PARTS ARE IN PROPER MECHANICAL ORDER, THAT THE OPERATOR IS LEVEL AND ALIGNED, AND THAT IT OPENS AND CLOSES PROPERLY. MAKE SURE YOU HAVE SUITABLE MECHANICAL STOPS • IF THE OPERATOR IS TO BE INSTALLED AT A HEIGHT OF LESS THAN 2.5 M FROM THE GROUND OR OTHER ACCESS LEVEL, MAKE SURE YOU HAVE ANY NECESSARY PROTECTIONS AND/OR WARNINGS IN PLACE • IF ANY PEDESTRIAN OPENINGS ARE FITTED INTO THE OPERATOR, THERE MUST ALSO BE A SYSTEM TO BLOCK THEIR OPENING WHILE THEY ARE MOVING • MAKE SURE THAT THE OPENING AUTOMATED DOOR OR GATE CANNOT ENTRAP PEOPLE AGAINST THE FIXED PARTS OF THE OPERATOR • DO NOT FIT UPSIDE DOWN OR ONTO ELEMENTS THAT COULD BEND. IF NECESSARY, ADD SUITABLE REINFORCEMENTS TO THE ANCHORING POINTS • DO NOT INSTALL DOOR OR GATE LEAVES ON TILTED SURFACES • MAKE SURE ANY SPRINKLER SYSTEMS CANNOT WET THE OPERATOR FROM THE GROUND UP • MAKE SURE THE TEMPERATURE RANGE SHOWN ON THE PRODUCT LITERATURE IS SUITABLE TO THE CLIMATE WHERE IT WILL BE INSTALLED • FOLLOW ALL INSTRUCTIONS AS IMPROPER INSTALLATION MAY RESULT IN SERIOUS BODILY INJURY • IT IS IMPORTANT TO FOLLOW THESE INSTRUCTIONS FOR THE SAFETY OF PEOPLE. KEEP THESE INSTRUCTIONS.

**INSTALLING**

• SUITABLY SECTION OFF AND DEMARCATÉ THE ENTIRE INSTALLATION SITE TO PREVENT UNAUTHORIZED PERSONS FROM ENTERING THE AREA, ESPECIALLY MINORS AND CHILDREN • BE CAREFUL WHEN HANDLING OPERATORS THAT WEIGH OVER 20 KG. IF NEED BE, USE PROPER SAFETY HOISTING EQUIPMENT • ALL OPENING COMMANDS (THAT IS, BUTTONS, KEY SWITCHES, MAGNETIC READERS, AND SO ON) MUST BE INSTALLED AT LEAST 1.85 M FROM THE PERIMETER OF THE GATE'S WORKING AREA, OR WHERE THEY CANNOT BE REACHED FROM OUTSIDE THE GATE. ALSO, ANY DIRECT COMMANDS (WHETHER BUTTONS, TOUCH PANELS, AND SO ON) MUST BE INSTALLED AT LEAST 1.5 M FROM THE GROUND AND MUST NOT BE REACHABLE BY UNAUTHORIZED PERSONS • ALL MAINTAINED ACTION COMMANDS, MUST BE FITTED IN PLACES FROM WHICH THE MOVING GATE LEAVES AND TRANSIT AND DRIVING AREAS ARE VISIBLE • APPLY, IF MISSING, A PERMANENT SIGN SHOWING THE POSITION OF THE RELEASE DEVICE • BEFORE DELIVERING TO THE USERS, MAKE SURE THE SYSTEM IS EN 12453 STANDARD COMPLIANT (REGARDING IMPACT FORCES), AND ALSO MAKE SURE THE SYSTEM HAS BEEN PROPERLY ADJUSTED AND THAT ANY SAFETY, PROTECTION AND MANUAL RELEASE DEVICES ARE WORKING PROPERLY • APPLY WARNING SIGNS WHERE NECESSARY AND IN A VISIBLE PLACE, (SUCH AS, SUCH AS THE GATE'S PLATE

**SPECIAL USER-INSTRUCTIONS AND RECOMMENDATIONS**





• KEEP GATE OPERATION AREAS CLEAN AND FREE OF ANY OBSTRUCTIONS. MAKE SURE THAT THE PHOTOCELLS ARE FREE OF ANY OVERTHROWN VEGETATION AND THAT THE OPERATOR'S AREA OF OPERATION IS FREE OF ANY OBSTRUCTIONS • DO NOT ALLOW CHILDREN TO PLAY WITH FIXED COMMANDS, OR TO LOITER IN THE GATE'S MANEUVERING AREA. KEEP ANY REMOTE CONTROL TRANSMITTERS OR ANY OTHER COMMAND DEVICE AWAY FROM CHILDREN, TO PREVENT THE OPERATOR FROM BEING ACCIDENTALLY ACTIVATED. • THE APPARATUS MAY BE USED BY CHILDREN OF EIGHT YEARS AND ABOVE AND BY PHYSICALLY, MENTALLY AND SENSORY-CHALLENGED PEOPLE, OR EVEN ONES WITHOUT ANY EXPERIENCE, PROVIDED THIS HAPPENS UNDER CLOSE SUPERVISION OR ONCE THEY HAVE BEEN PROPERLY INSTRUCTED TO USE THE APPARATUS SAFELY AND TO THE POTENTIAL HAZARDS INVOLVED. CHILDREN MUST NOT PLAY WITH THE APPARATUS. CLEANING AND MAINTENANCE BY USERS MUST NOT BE DONE BY CHILDREN, UNLESS PROPERLY SUPERVISED • FREQUENTLY CHECK THE SYSTEM FOR ANY MALFUNCTIONS OR SIGNS OF WEAR AND TEAR OR DAMAGE TO THE MOVING STRUCTURES, TO THE COMPONENT PARTS, ALL ANCHORING POINTS, INCLUDING CABLES AND ANY ACCESSIBLE CONNECTIONS. KEEP ANY HINGES, MOVING JOINTS AND SLIDE RAILS PROPERLY LUBRICATED • PERFORM FUNCTIONAL CHECKS ON THE PHOTOCELLS AND SENSITIVE SAFETY EDGES, EVERY SIX MONTHS. TO CHECK WHETHER THE PHOTOCELLS ARE WORKING, WAVE AN OBJECT IN FRONT OF THEM WHILE THE

GATE IS CLOSING; IF THE OPERATOR INVERTS ITS DIRECTION OF TRAVEL OR SUDDENLY STOPS, THE PHOTOCELLS ARE WORKING PROPERLY. THIS IS THE ONLY MAINTENANCE OPERATION TO DO WITH THE POWER ON. CONSTANTLY CLEAN THE PHOTOCELLS' GLASS COVERS USING A SLIGHTLY WATER-MOISTENED CLOTH; DO NOT USE SOLVENTS OR OTHER CHEMICAL PRODUCTS THAT MAY RUIN THE DEVICES • IF REPAIRS OR MODIFICATIONS ARE REQUIRED TO THE SYSTEM, RELEASE THE OPERATOR AND DO NOT USE IT UNTIL SAFETY CONDITIONS HAVE BEEN RESTORED • CUT OFF THE POWER SUPPLY BEFORE RELEASING THE OPERATOR FOR MANUAL OPENINGS AND BEFORE ANY OTHER OPERATION, TO PREVENT POTENTIALLY HAZARDOUS SITUATIONS. READ THE INSTRUCTIONS IF THE POWER SUPPLY CABLE IS DAMAGED, IT MUST BE REPLACED BY THE MANUFACTURER OR AUTHORIZED TECHNICAL ASSISTANCE SERVICE, OR IN ANY CASE, BY SIMILARLY QUALIFIED PERSONS, TO PREVENT ANY RISK • IT IS FORBIDDEN FOR USERS TO PERFORM ANY OPERATIONS THAT ARE NOT EXPRESSLY REQUIRED OF THEM AND WHICH ARE NOT LISTED IN THE MANUALS. FOR ANY REPAIRS, MODIFICATIONS / ADJUSTMENTS, AND FOR EXTRA-ORDINARY MAINTENANCE, CALL TECHNICAL ASSISTANCE • LOG THE JOB AND CHECKS INTO THE PERIODIC MAINTENANCE LOG.

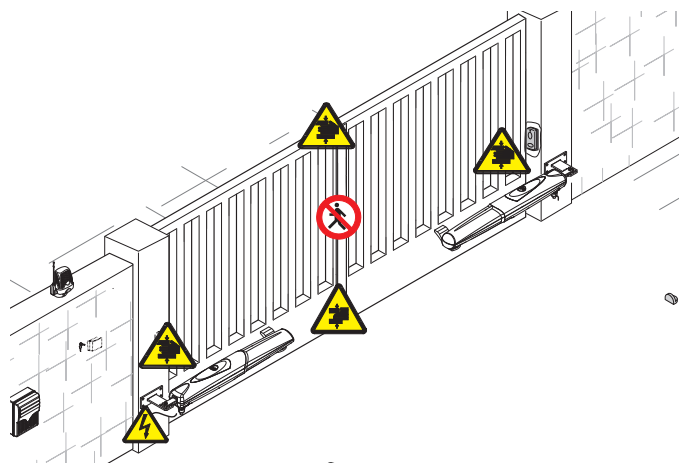

**FURTHER RECOMMENDATIONS FOR ALL**

• KEEP CLEAR OF HINGES AND MECHANICAL MOVING PARTS • DO NOT ENTER THE OPERATOR'S AREA OF OPERATION WHEN IT IS MOVING • DO NOT COUNTER THE OPERATOR'S MOVEMENT AS THIS COULD RESULT IN DANGEROUS SITUATIONS • ALWAYS PAY SPECIAL ATTENTION TO ANY DANGEROUS POINTS, WHICH HAVE TO BE LABELED WITH SPECIFIC PICTOGRAMS AND/OR BLACK AND YELLOW STRIPES • WHILE USING A SELECTOR SWITCH OR A COMMAND IN MAINTAINED ACTIONS, KEEP CHECKING THAT THERE ARE NO PERSONS WITHIN THE OPERATING RANGE OF ANY MOVING PARTS, UNTIL THE COMMAND IS RELEASED • THE GATE MAY MOVE AT ANY TIME AND WITHOUT WARNING • ALWAYS CUT OFF THE MAINS POWER SUPPLY BEFORE PERFORMING ANY MAINTENANCE OR CLEANING.



-  Danger of foot crushing
-  Danger of hand crushing
-  Danger! High voltage.
-  No transiting while the barrier is moving

## LEGEND

-  This symbol shows which parts to read carefully.
-  This symbol shows which parts describe safety issues
-  This symbol shows which parts to tell users about.

## DESCRIPTION

AX3024 Irreversible gearmotor for swing gates with leaves of up to 3 m long.  
AX5024 Irreversible gearmotor for swing gates with leaves of up to 5 m long.

### Intended use

This gearmotor is designed to power and operate swing gates in private homes and apartment blocks.

 Any installation and/or use other than that specified in this manual is forbidden.

### Limits to use

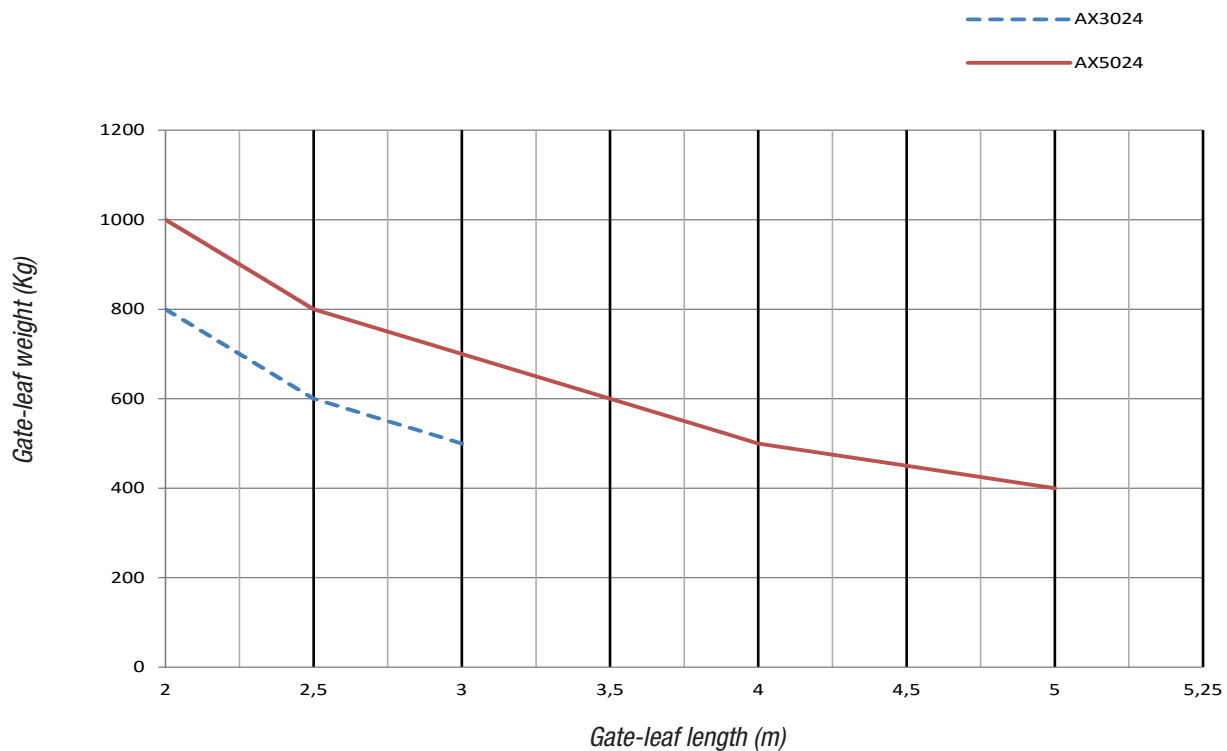

 For swing gates, installing an electric lock is always recommended. This is to ensure the leaves close reliably and to protect the gearmotor parts. It is also recommended for irreversible gearmotors – and is mandatory where the leaves are more than 2.5 m in length.

For reversible gearmotors, electric locks are required to ensure the leaves close. The installer is responsible for installing an electric lock, taking into account the size and type of leaf (e.g. panelled) and the installation area (e.g. windy location).

### Technical data

Type	AX3024 / AX5024
Protection rating (IP)	44
Power supply (V - 50/60 Hz)	230 AC
Power supply motor (V)	24 DC
Max draw (A)	10
Power (W)	120
Thrust (N)	500 ÷ 4500
Opening time at 90° (s)	ADJUSTABLE
Duty cycle (%)	INTENSIVE SERVICE
Operating temperature (°C)	-20 ÷ +55
Motor's thermal monitoring (°C)	150
Weight (Kg)	-

## Dimensions

(mm)

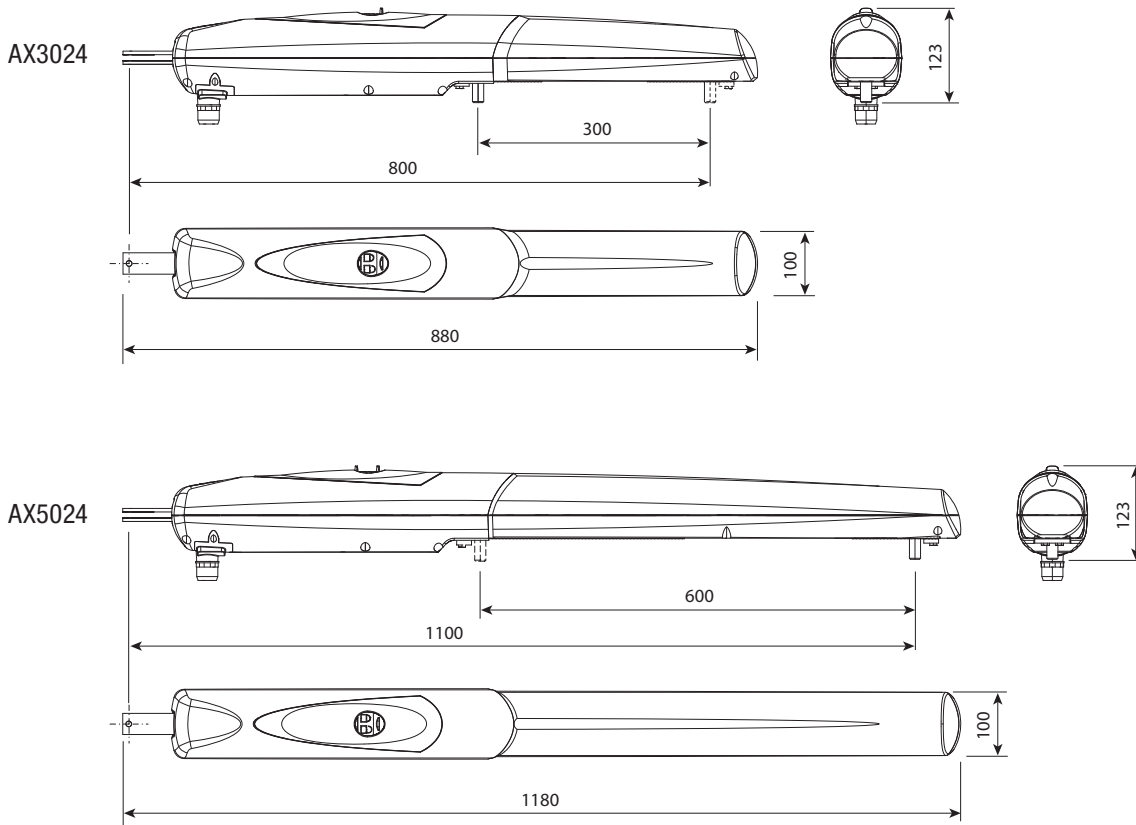

## Description of parts

1. Operator
2. Pilaster bracket
3. Gate bracket
4. M8x35 UNI5737 screw for securing pillar bracket
5. Bushing
6. M8 UNI5588 nut for securing pillar bracket
7. Sheath holder
8. Mechanical stop
9. M6X20 UNI5739 screws for mechanical stop
10. Endless screw pin
11. Ø8x24 UNI6593 washer
12. Gate bracket screw for securing to M8x10 UNI5739 pin
13. Securing bracket
14. Small release door

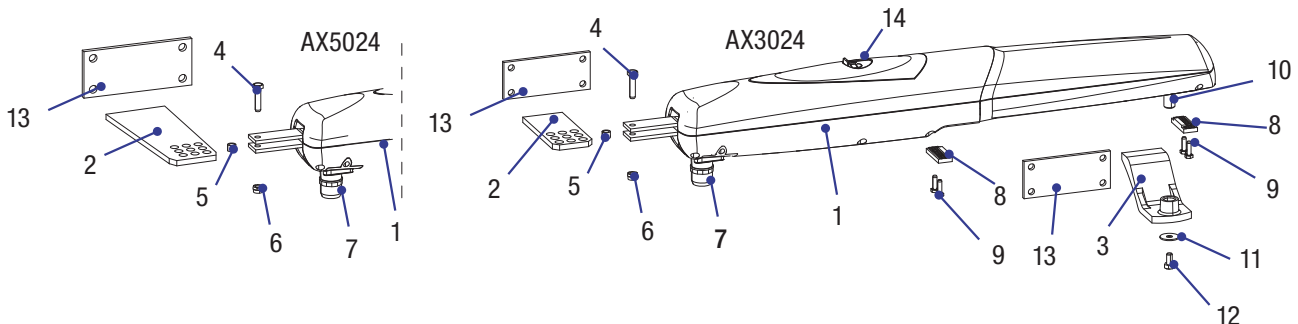

## Standard installation

1. AXO operator
2. Control panel
3. Reception antenna
4. Flashing light
5. Selector switch
6. Photocells
7. Electric cable junction box
8. Mechanical gate stops
9. Photocell column

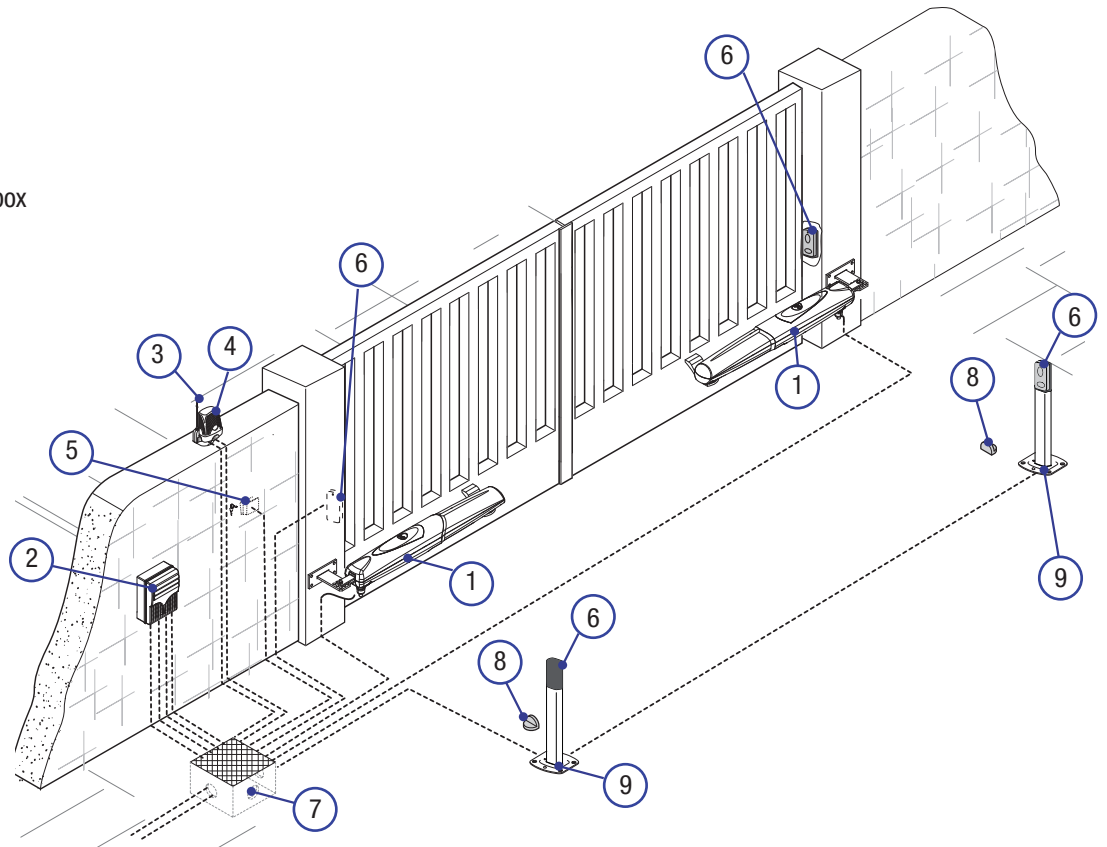

## GENERAL INSTALLATION INDICATIONS

⚠ Only skilled, qualified staff must install this product.

### Preliminary checks

⚠ Before beginning, do the following:

- check that the gate structure is sturdy enough, the hinges work efficiently and that there is no friction between the fixed and moving parts;
- make sure that measurement C does not exceed the value shown in the reference table;
- make sure you have fitted opening and closing mechanical gate stops;
- make sure that the point where the gearmotor is fastened is protected from any impacts and that the anchoring surface is solid enough;
- make sure you have set up a suitable dual pole cut off device along the power supply that is compliant with the installation rules. It should completely cut off the power supply according to category III surcharge conditions (that is, with minimum contact openings of 3 mm);
- ⊕ make sure that any connections inside the container (ones that ensure continuity to the protection circuit) are fitted with additional insulation with respect to those of other electrical parts inside;
- set up suitable tubes and conduits for the electric cables to pass through, making sure they are protected from any mechanical damage.

### Tools and materials

Make sure you have all the tools and materials you will need for installing in total safety and in compliance with applicable regulations. The figure shows some of the equipment installers will need.

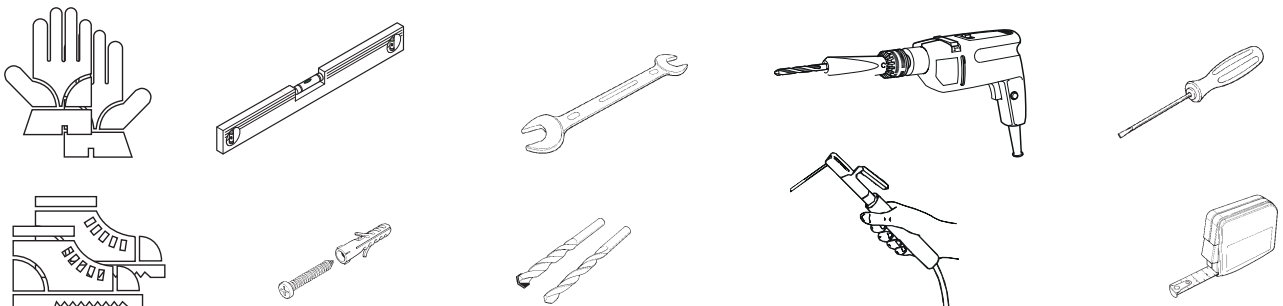

## Cable types and minimum thicknesses

Connection	Cable type	Cable length 1 < 15 m	Cable length 15 < 30 m
Control panel power supply 230 V AC	H05RN-F	3G x 1,5 mm <sup>2</sup>	3G x 2,5 mm <sup>2</sup>
Power supply to motor 24 V AC	FROR CEI 20-22 CEI EN 50267-2-1	4G x 1,5 mm <sup>2</sup>	4G x 2,5 mm <sup>2</sup>
Flashing light		2 x 0,5 mm <sup>2</sup>	
Photocell transmitters		2 x 0,5 mm <sup>2</sup>	
Photocell receivers		4 x 0,5 mm <sup>2</sup>	
Command and safety device		2 x 0,5 mm <sup>2</sup>	
Antenna	RG58	max 10 m	

📖 If cable lengths differ from those specified in the table, establish the cable sections depending on the actual power draw of the connected devices and according to the provisions of regulation CEI EN 60204-1.

For multiple, sequential loads along the same line, the dimensions on the table need to be recalculated according to the actual power draw and distances. For connecting products that are not contemplated in this manual, see the literature accompanying said products.

## INSTALLATION

⚠ The following illustrations are just examples, in that the space available for fitting the operator and accessories varies depending on the overall dimensions. It is up to the installer to find the most suitable solution.

📖 The drawings refer to the left-side gearmotor. Install the operator on the right, symmetrically.

### Corrugated tube laying

Fit junction boxes and corrugates tubes for incoming connections from the junction pit.

📖 The number of tubes depends on the type of system and the accessories you are going to fit.

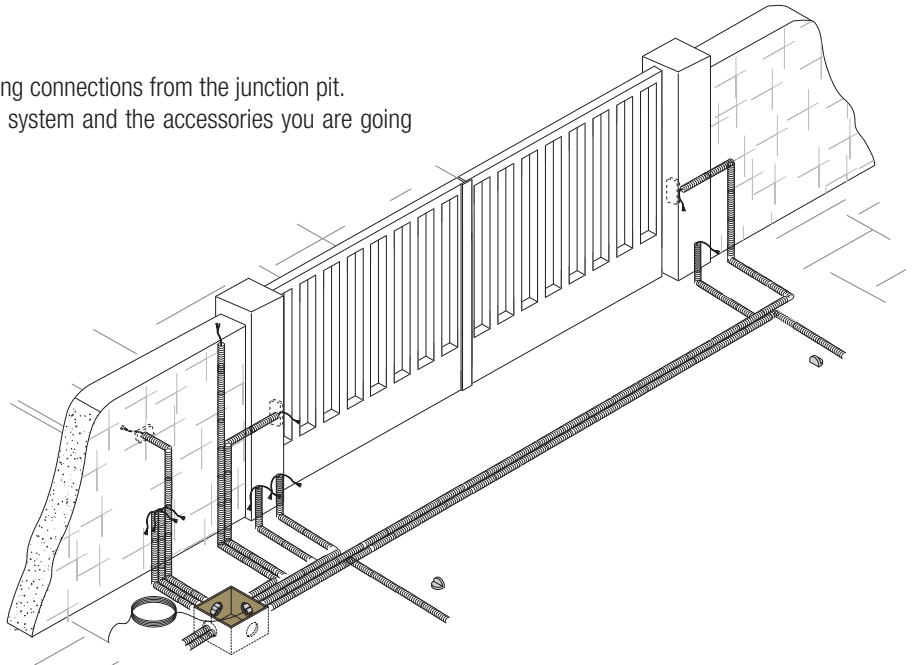

### Fastening the braces

Establish the point the gate and post braces will be fitted, while respecting the quotas shown on the table.

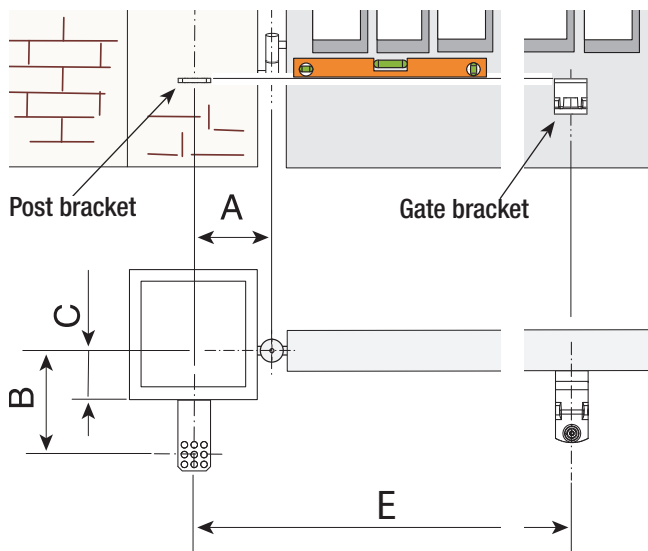

AX3024

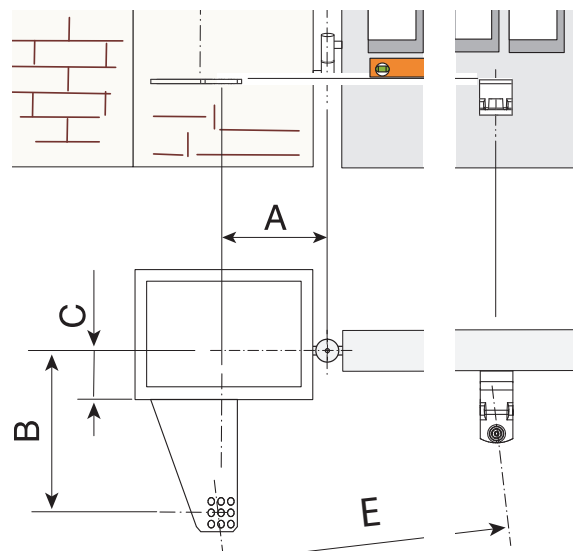

AX5024

Application dimension (mm)

AX3024				
Leaf opening arc (°)	A	B	C MAX	E
90°	130	130	70	
120°	150	80	0	800
120°	140	100	50	

  

AX5024				
Leaf opening arc (°)	A	B	C MAX	E
90°	200		150	
120°	220	220	100	1100

 The greater the gate leaf's opening angle, the greater the opening speed and the slower is the gearmotor's thrust. The smaller the gate leaf's opening angle, the slower the opening speed and the greater is the gearmotor's thrust.

Assemble and weld the two parts of the post brace.

Fasten the brace to the established point, using suitable plugs and screws. If the post is metallic, weld the brace.

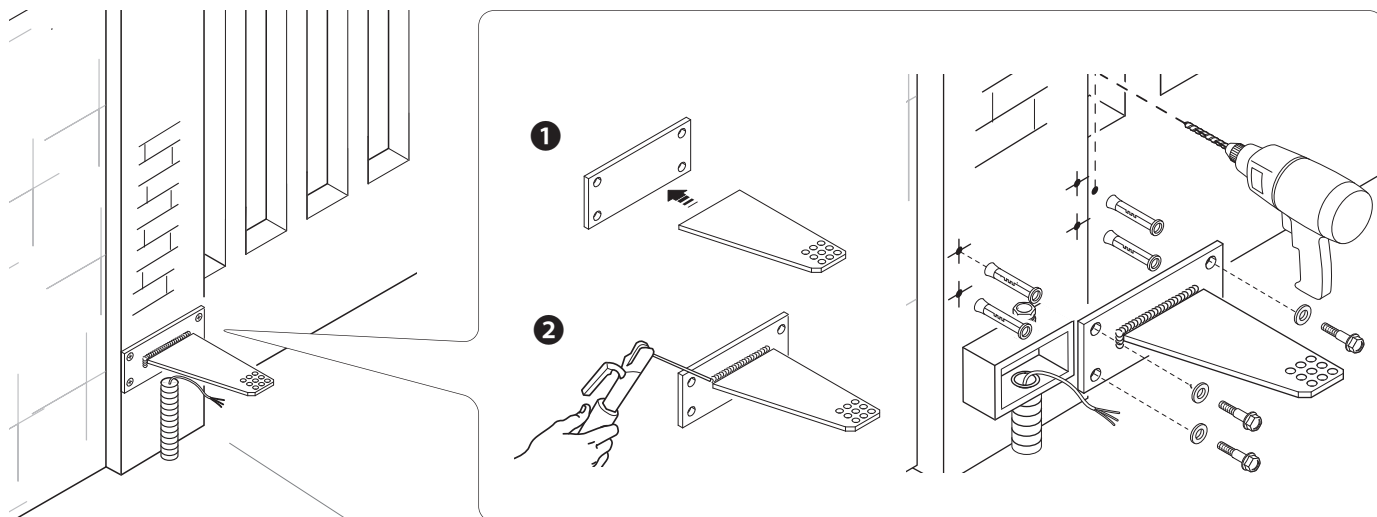
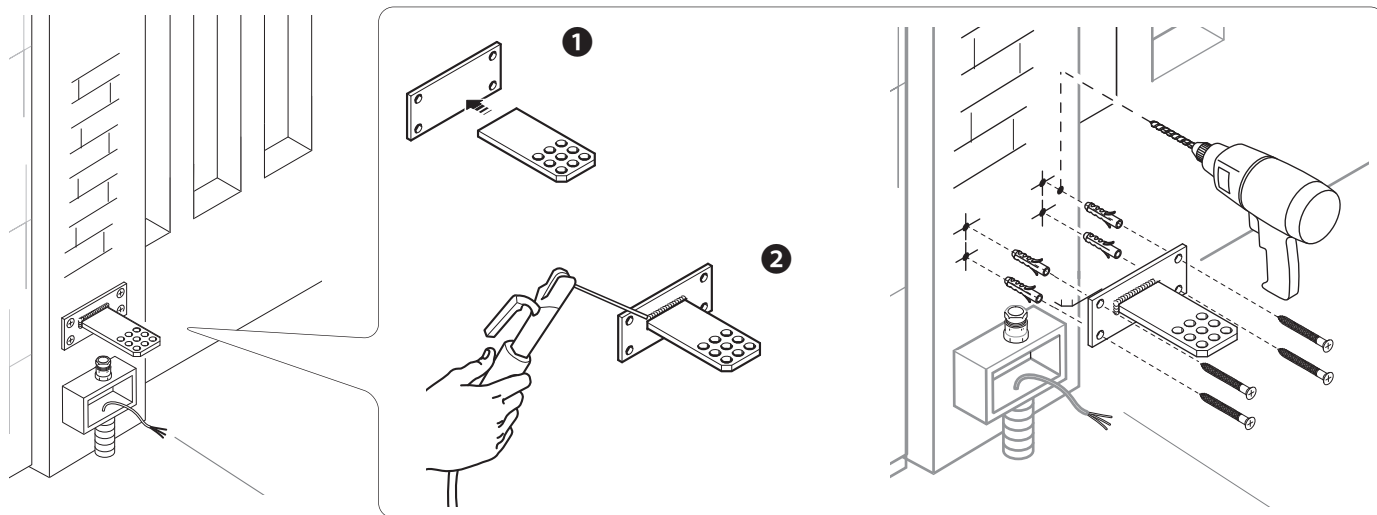

Weld the gate bracket to the gate leaf making sure the quotas shown in the table are met.  
 Note: for AX5024 gearmotors, require an additional 10 mm shim between the gate and the bracket.

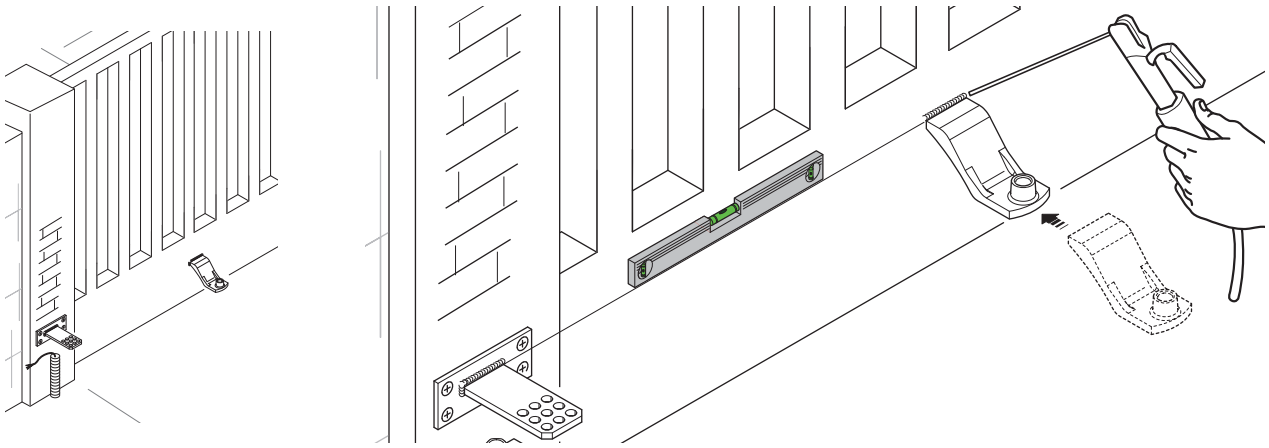

Note: on non-metal gate leaves assemble and weld the two parts of the bracket and secure them with proper screws. Secure the tail joint to the bracket.

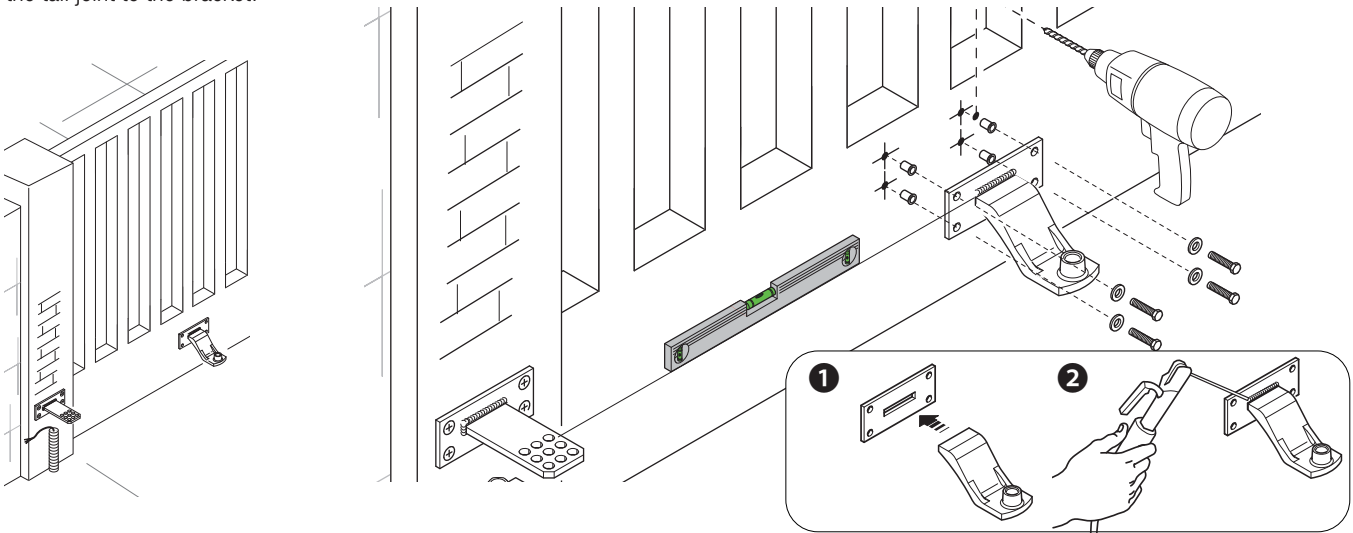

Insert the bushing (lubricated) into the pillar bracket's hole. The bracket has holes that allow the opening angle to be changed. Secure the tail joint to the bracket.

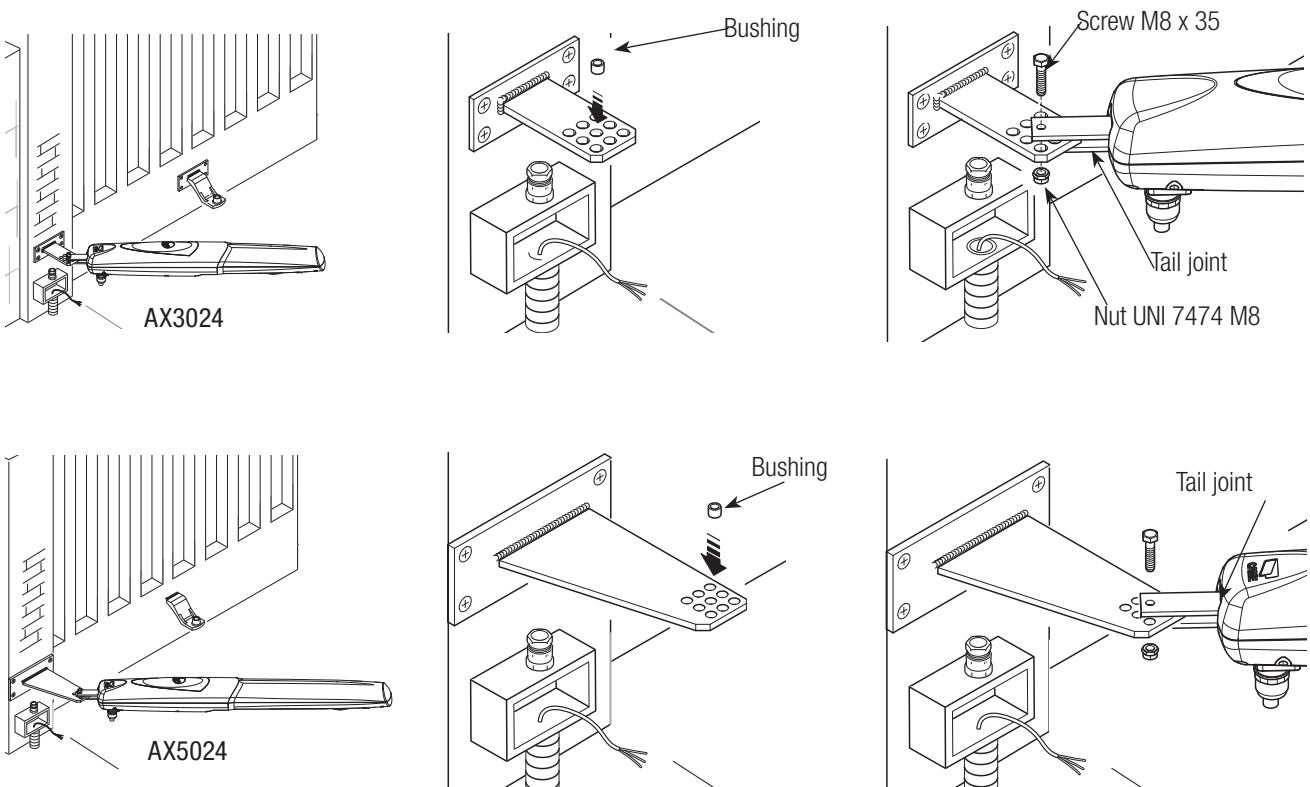

Open the gate leaf and insert the pin into the gate bracket and secure it using a washer and nut.

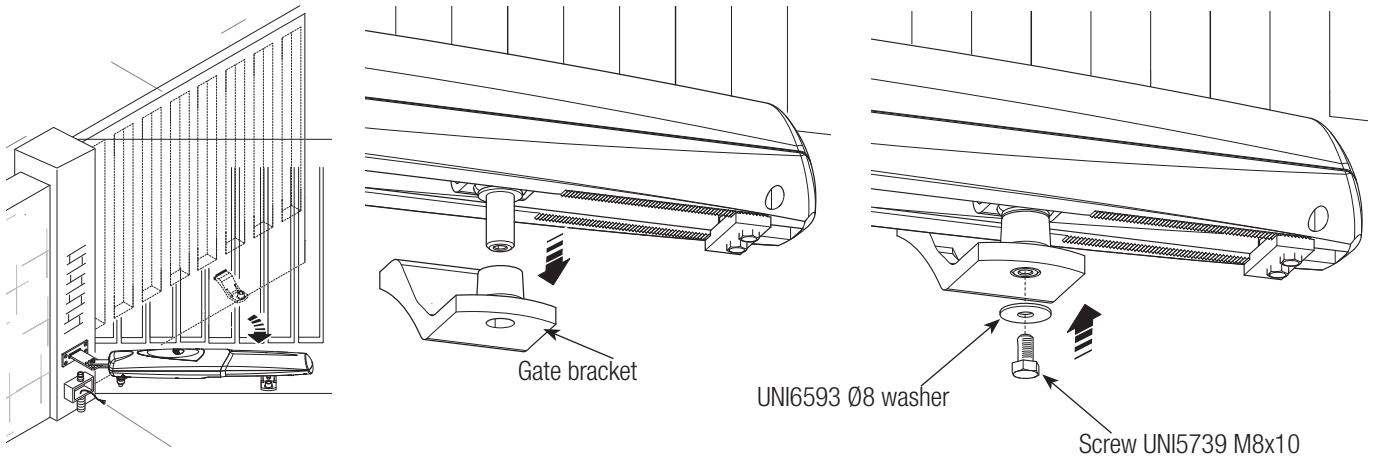

Release the gearmotor (see paragraph on manual release), completely open the gate leaf, loosen the nuts of the opening mechanical stop and position it up against the attachment pin, then secure it.

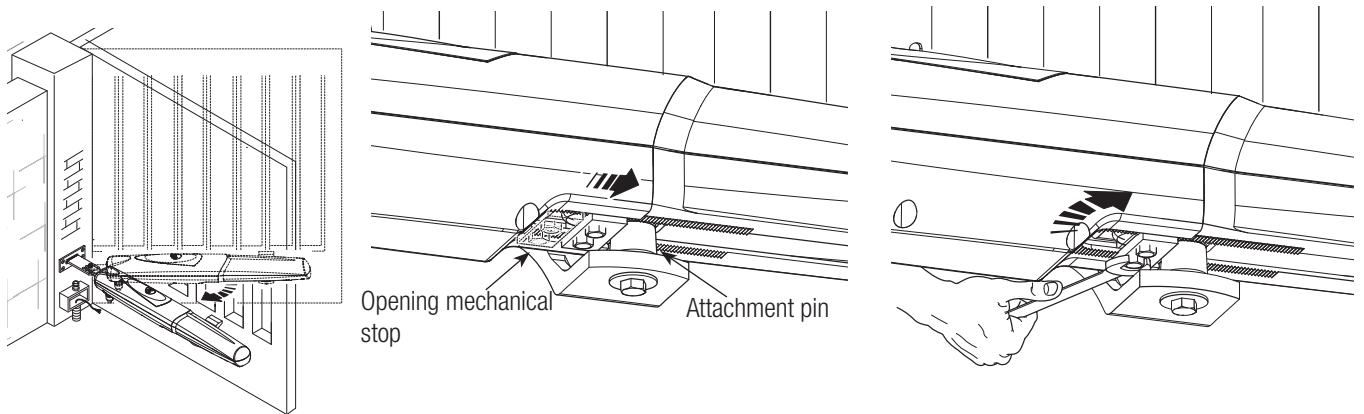

Close the gate leaf, loosen the nuts on the closing mechanical stop, place it up against the attachment pin, then secure it.

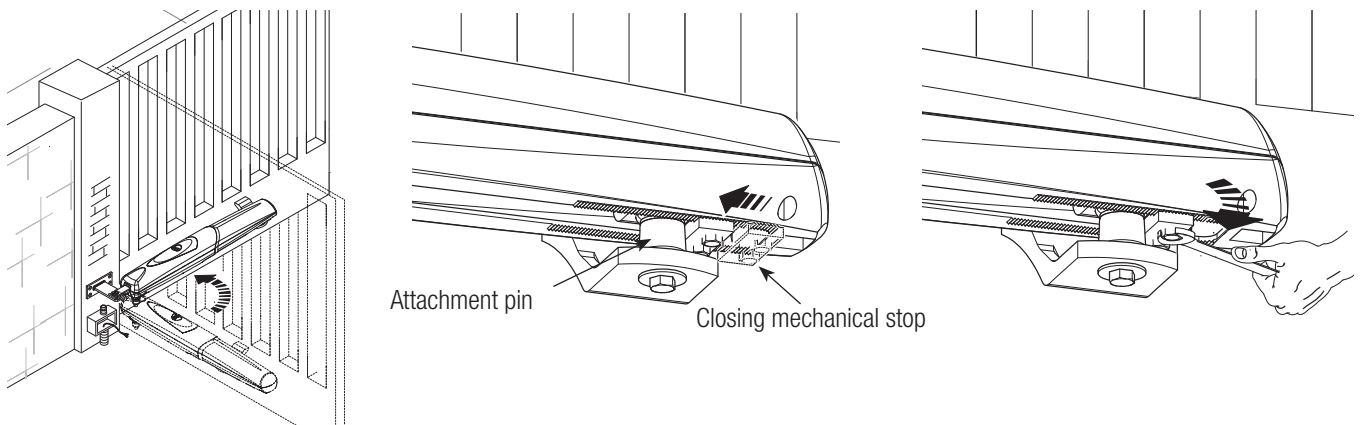

## RELEASING THE GEARMOTOR

⚠ This procedure must be done with the main power cut off.

⚠ The gearmotor's manual release may cause unwanted movement of the gate, if the latter has any mechanical issues or if it is not balanced.

Slide open the small door that protects the release, insert the tri-lobed key and turn it.

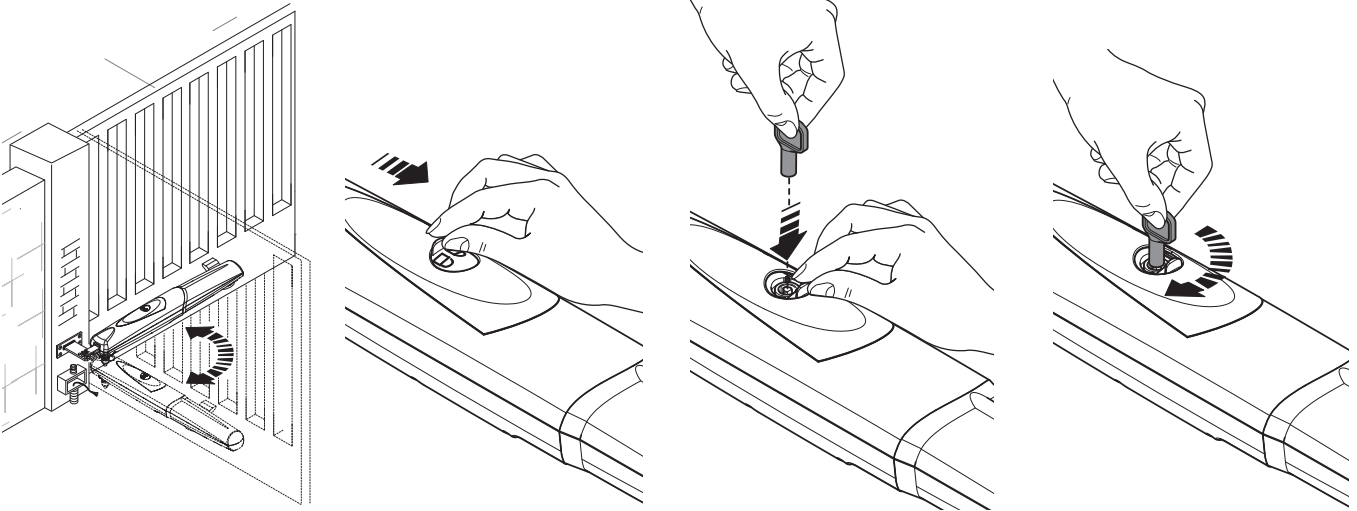

## Connecting to the control panel

⚠ Warning! Before working on the control panel, cut off the main current supply and, if present, remove any batteries.

For the electrical connection procedures, use the junction box and branching boxes.

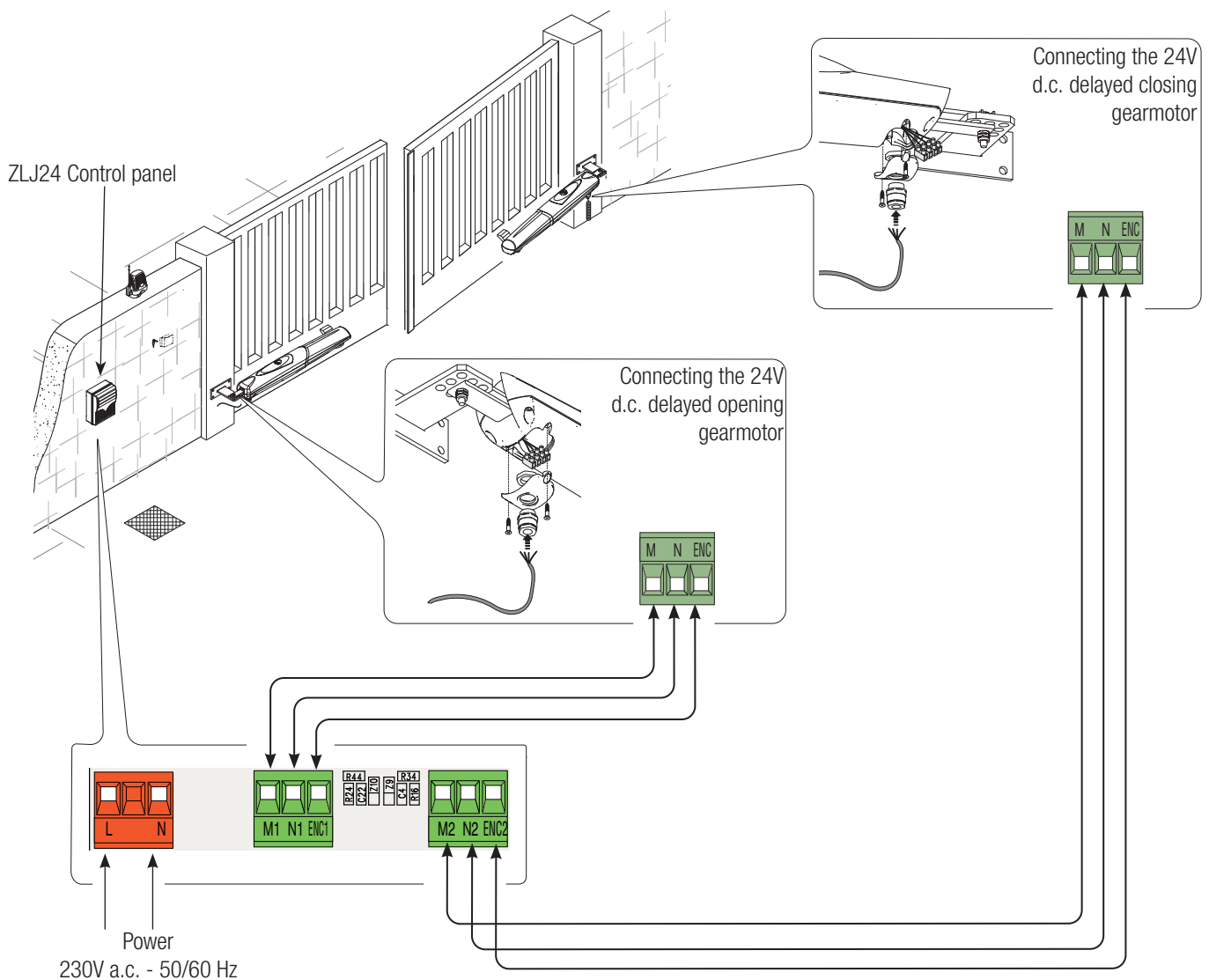

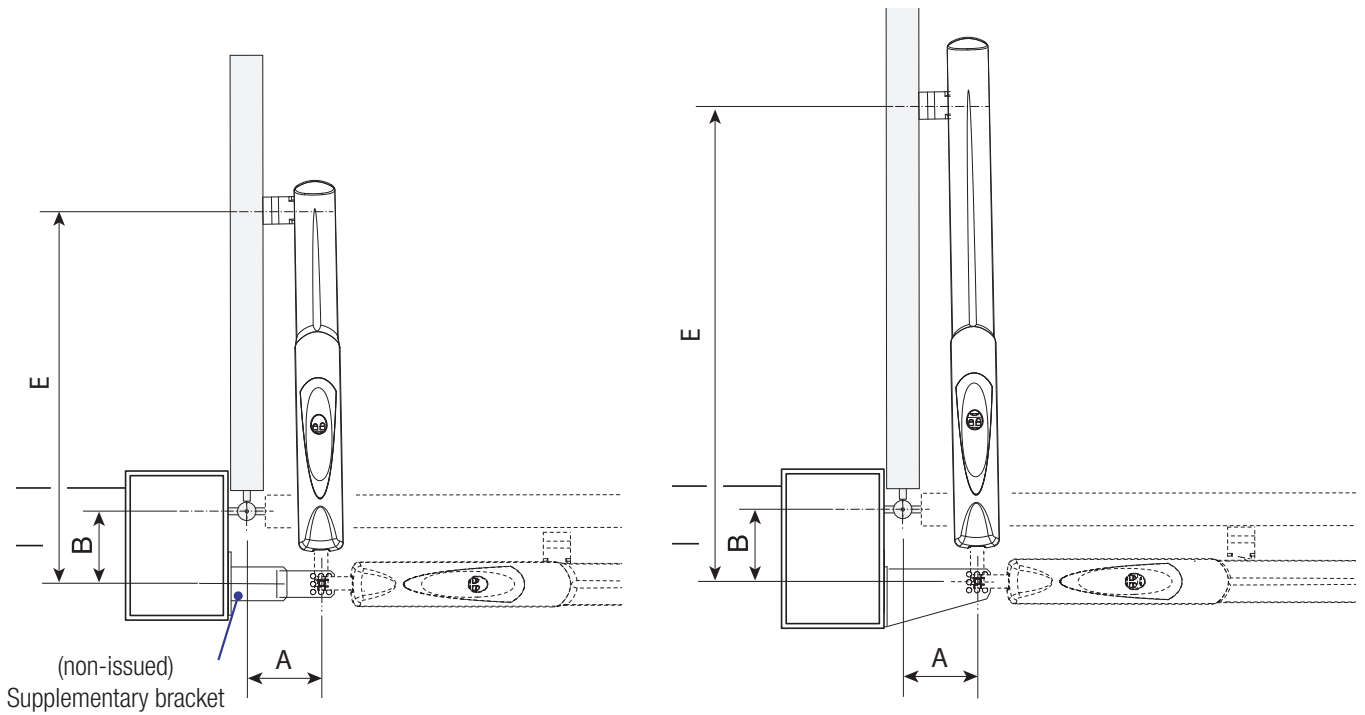

TABLE 1

Opening	A (mm)	B (mm)	E (mm)
90°	130	130	800

TABLE 2

Opening	A (mm)	B (mm)	E (mm)
90°	200	220	1100

**Fastening the braces**

Weld pillar bracket to the non-issued supplementary bracket, while gate is open, then secure the brackets to the pillar, making sure the “A” and “B” quotas shown in table 1 are met. Weld, or secure with proper screws, the gate bracket, making sure the “E” quota is met, as shown in table 1. Finally, secure the gearmotor to the brackets with the issued screws and washers.

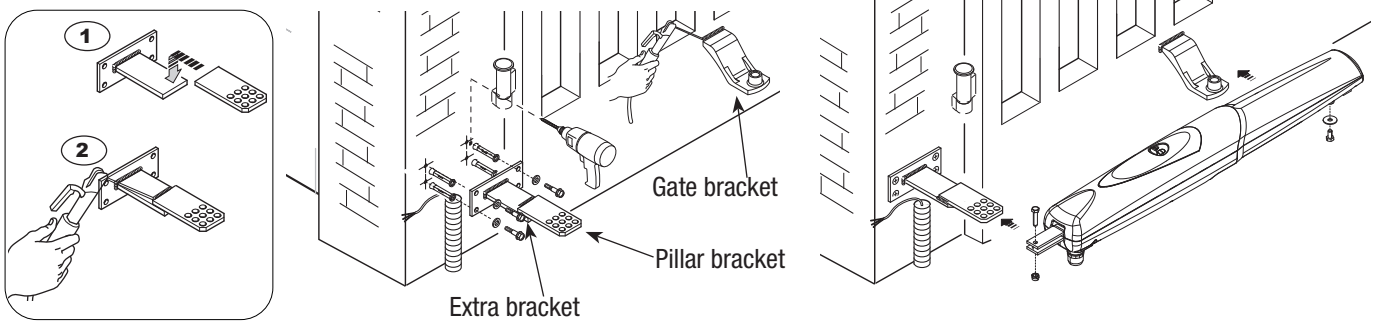

For AX5024 gearmotors, directly secure the standard issue bracket to the pillar without using the supplementary bracket, while taking into account the measurements shown in table 2.

Finally, secure the gearmotor to the brackets with the issued screws and washers.

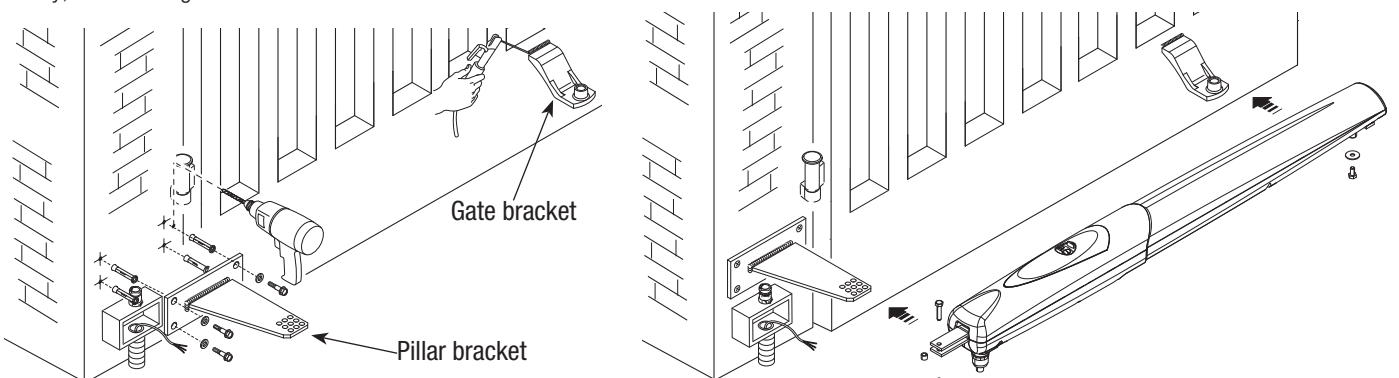

Fully close the gate-leaf, place the mechanical stop against it with the pin attachment and fix it in place.

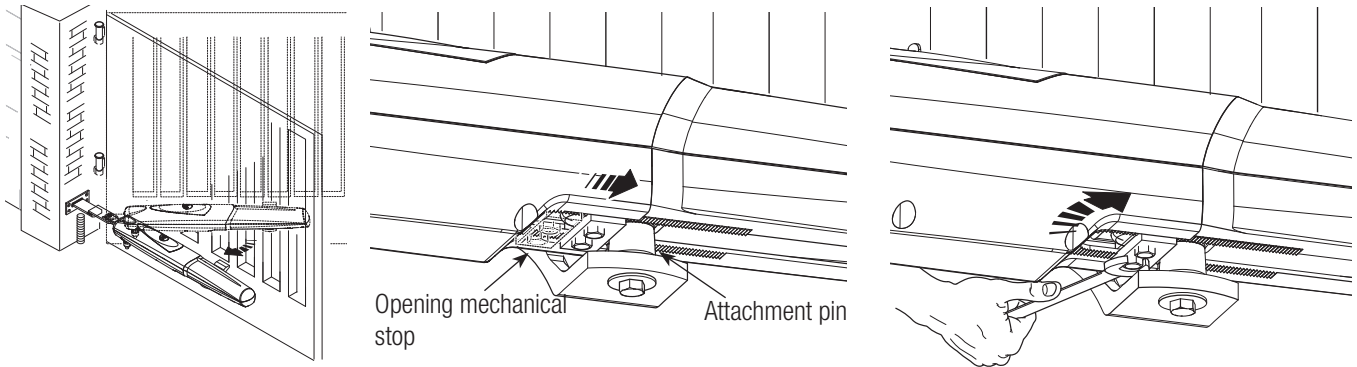

Fully open the gate-leaf, place the mechanical stop against it with the pin attachment and fix it in place.

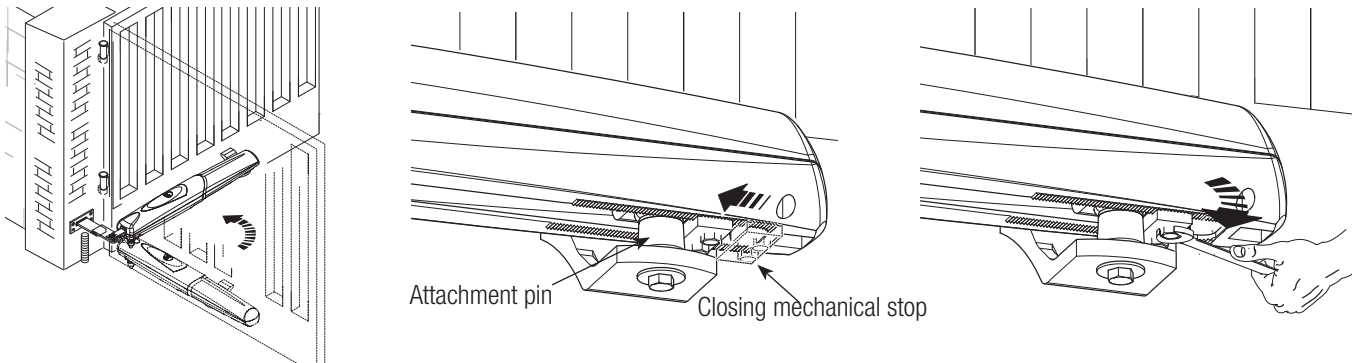

Connect the gearmotors to the panel as shown in the diagram.

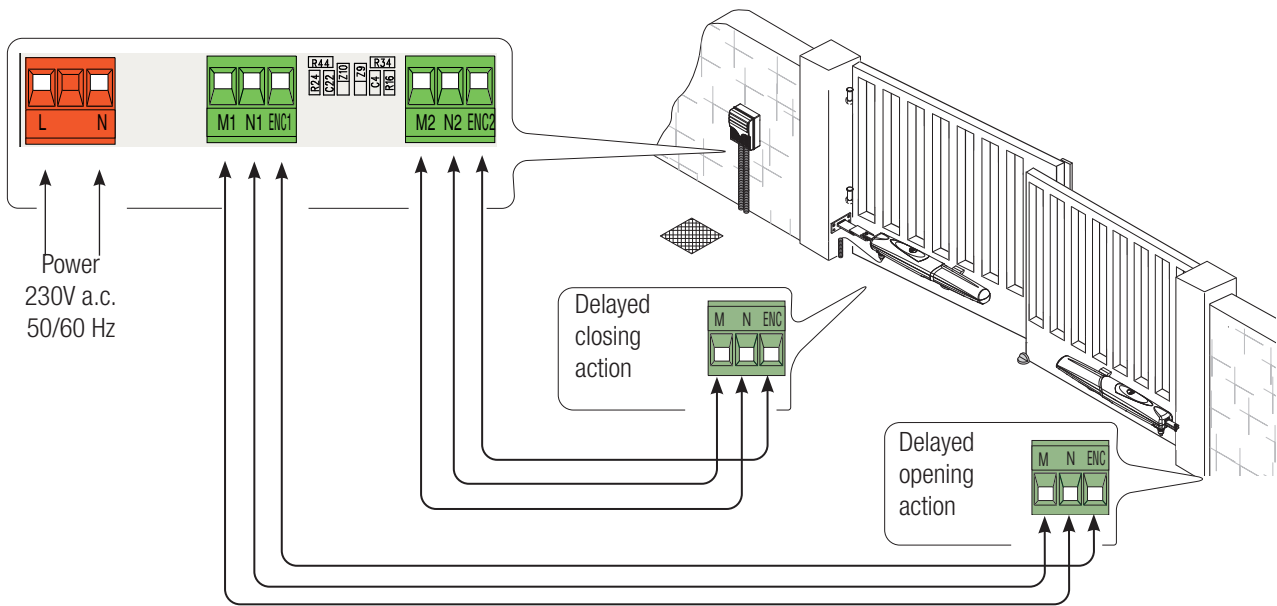

## TROUBLESHOOTING

TROUBLES	POSSIBLE CAUSES	FIXES
It neither opens nor closes	<ul style="list-style-type: none"> <li>• Power supply missing</li> <li>• The gearmotor is stuck</li> <li>• The transmitter's battery is run down</li> <li>• The transmitter is broken</li> <li>• The stop button is either stuck or broken</li> <li>• The opening/closing button or the key-switch selector is stuck</li> </ul>	<ul style="list-style-type: none"> <li>• Check main power supply</li> <li>• Lock the gearmotor</li> <li>• Replace the batteries</li> <li>• Call for assistance</li> <li>• Call for assistance</li> <li>• Call for assistance</li> </ul>
The gate opens but does not close	<ul style="list-style-type: none"> <li>• The photocells are soiled.</li> </ul>	<ul style="list-style-type: none"> <li>• Clean and check that the photocells work properly. Otherwise call for assistance</li> </ul>
The Flashing light does not work	<ul style="list-style-type: none"> <li>• The bulb is burnt</li> </ul>	<ul style="list-style-type: none"> <li>• Call assistance</li> </ul>



**Extraordinary maintenance**

△ The following table is for logging any extraordinary maintenance jobs, repairs and improvements performed by specialized contractors.

📖 Any extraordinary maintenance jobs must be done only by specialized technicians.

**Extraordinary maintenance log**

Fitter's stamp	Name of operator
	Job performed on (date)
	Technician's signature
	Requester's signature
Job performed _____ _____ _____	

Fitter's stamp	Name of operator
	Job performed on (date)
	Technician's signature
	Requester's signature
Job performed _____ _____ _____	

Fitter's stamp	Name of operator
	Job performed on (date)
	Technician's signature
	Requester's signature
Job performed _____ _____ _____	

Fitter's stamp	Name of operator
	Job performed on (date)
	Technician's signature
	Requester's signature
Job performed _____ _____ _____	

Fitter's stamp	Name of operator
	Job performed on (date)
	Technician's signature
	Requester's signature
Job performed _____ _____ _____	

Fitter's stamp	Name of operator
	Job performed on (date)
	Technician's signature
	Requester's signature
Job performed _____ _____ _____	

## DISMANTLING AND DISPOSAL

☞ CAME S.p.A. applies a certified Environmental Management System at its premises, which is compliant with the UNI EN ISO 14001 standard to ensure the environment is safeguarded.

Please continue safeguarding the environment. At CAME we consider it one of the fundamentals of our operating and market strategies. Simply follow these brief disposal guidelines:

### ♻️ DISPOSING OF THE PACKAGING

The packaging materials (cardboard, plastic, and so on) should be disposed of as solid urban waste, and simply separated from other waste for recycling.

Always make sure you comply with local laws before dismantling and disposing of the product.

DO NOT DISPOSE OF IN NATURE!

### ♻️ DISMANTLING AND DISPOSAL

Our products are made of various materials. Most of these (aluminum, plastic, iron, electrical cables) is classified as solid household waste. They can be recycled by separating them before dumping at authorized city plants.

Whereas other components (control boards, batteries, transmitters, and so on) may contain hazardous pollutants.

These must therefore be disposed of by authorized, certified professional services.

Before disposing, it is always advisable to check with the specific laws that apply in your area.

DO NOT DISPOSE OF IN NATURE!

## DECLARATION OF CONFORMITY

The product complies with the applicable reference directives.

*The contents of this manual may change, at any time, and without notice.*



**CAME.COM**

**CAME S.P.A.**

Via Martiri Della Libertà, 15

31030 Dosson di Casier - Treviso - Italy

tel. (+39) 0422 4940 - fax. (+39) 0422 4941